

Water sampling station **EASYPRO** for industrial applications



Reliable and individual

Designed to meet your every need, the **EASYPRO** system monitors and controls a range of water parameters in your industrial application.

The **TOPAX[®] MC** multi-channel controller installed* in the **EASYPRO** subjects the water parameters to constant measurement, keeping them within the target range. It enables you to control a large number of actuators and permits easy and intuitive operation.

The multi-coloured LEDs provide an optical warning if the water parameters leave the target range. Automatic continuous recording of the water parameters and depiction of their development permit simple diagnosis.

Dimensions

EASYPRO 1 & 2, all dimensions in mm

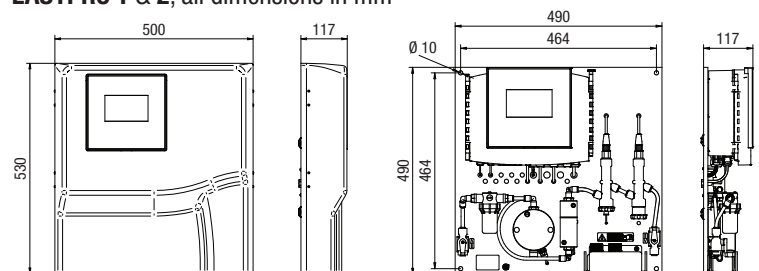

EASYPRO 3 & 4, all dimensions in mm

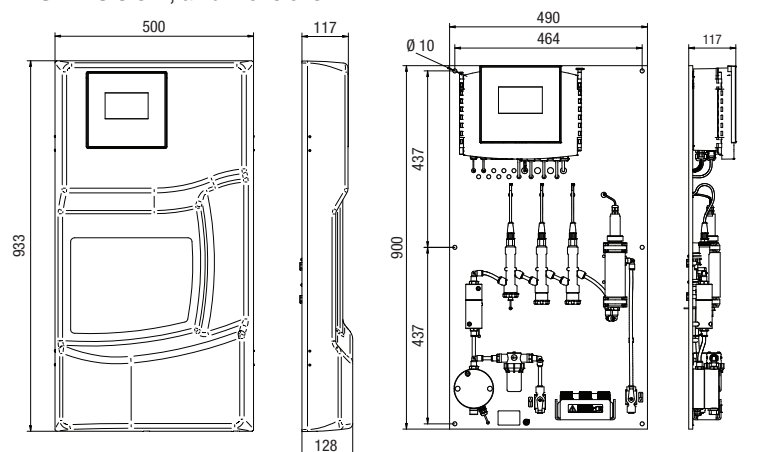

* Our standard versions are delivered with the **TOPAX[®] MC** multi-channel controller. Use the match code ordering system to order the **EASYPRO** water sampling stations without the **TOPAX[®] MC**.

Technical data, spare parts and accessories

EASYPRO			1	2	3	4
Sample water requirement	with CS120 excess chlorine measuring cell	l/h	45 approx.			
	with all other measuring cells	l/h	30 approx.			
Sample water inflow and discharge		mm	PE hose 6/8 + stop valve with G1/4 connection			
Pressure resistance	with diaphragm covered measuring cell	bar	max. 6, air gap required			
	with all other measuring cells		max. 6			
Pressure loss in the water sampling station		bar	0.3 approx.			
Mesh size sample water filter		µm	300			
Voltage supply			100 – 240 V AC, 50/60 Hz			
Power consumption		W	max. 20			
Analogue outputs for remote transmission			4 x 0/4 – 20 mA, working resistance max. 500 Ω			
Disturbance variable input		mA	0/4 – 20			
Interfaces			Ethernet TCP/IP or RS485 Modbus RTU (optional)			
Protection class			IP65 (electronic controller)			
Ambient temperature		°C	-5 to +45 (no exposure to direct sunlight)			
Control characteristic			P, PI, PID or PD behaviour, control direction selectable with disturbance variable feed forward, 2-side control selectable			
Measuring inputs (depending on version)						
Number of measuring inputs			1	2*	3**	4***
Bromine	Diaphragm covered measuring cell	mg/l	0 – 5 (dependant on the measuring cell)			
Free chlorine	Amperometric 3-electrode measuring cell with potentiostat (DMZ3.1)	mg/l	0 – 15 (dependant on the measuring cell transconductance)			
	CS120 excess chlorine measuring cell	mg/l	0 – 10 (dependant on the measuring cell transconductance)			
	Diaphragm covered measuring cell	mg/l	0 – 10 (dependant on the measuring cell)			
Chlorine dioxide	Amperometric 3-electrode measuring cell with potentiostat (DMZ3.1)	mg/l	0 – 15 (dependant on the measuring cell transconductance)			
	CS120 excess chlorine measuring cell	mg/l	0 – 10 (dependant on the measuring cell transconductance)			
	Diaphragm covered measuring cell	mg/l	0 – 2 (dependant on the measuring cell)			
Total chlorine	Diaphragm covered measuring cell	mg/l	0 – 10 (dependant on the measuring cell)			
Ozone	Diaphragm covered measuring cell	mg/l	0 – 2 (dependant on the measuring cell)			
pH value	pH single-rod measuring cell	pH	2 – 12 or 0 – 14 (depending on the single-rod measuring chain)			
Redox value	Redox single-rod measuring cell	mV	0 – 1000			
Chlorite	Diaphragm covered measuring cell	mg/l	0 – 2 (dependant on the measuring cell)			
Hydrogen peroxide	Diaphragm covered measuring cell	mg/l	0 – 200 (dependant on the measuring cell)			
Temperature	Pt100	°C	5 – 45			
Output modules (depending on version)						
Number of output modules			up to 4			
Servomotor relay			2 x 230 V AC, 5 A (ohmic load)			
		kΩ	Potentiometer feedback: 1 – 10			
Servomotor 20 mA			Constant 0/4 – 20 mA output			
			Servomotor with 20 mA feedback			
Relays			2 x 230 V AC, 5 A (ohmic load)			
Optocoupler			2 x 80 V DC, 5 mA			

* A temperature sensor can also be connected.

** Additionally, up to two temperature sensors can be connected.

*** Additionally, up to three temperature sensors can be connected.



Photometer

- For free chlorine and pH value
- Internal memory for 16 data sets
- Automatic switch off
- and much more...



Buffer solutions

- pH value: pH 6.80 and 9.27
- Redox value: 468 mV
- Electrolytes for diaphragm covered measuring cells