

EASYCHLORGEN

Safe, reliable & efficient on-site generation of sodium hypochlorite



The safe generation of sodium hypochlorite

EASYCHLORGEN sodium hypochlorite systems generate sodium hypochlorite from brine by electrolysis. The sodium hypochlorite has a concentration of approx. 0.5 – 0.8 %.

As the sodium hypochlorite solution produced is very low on minerals, extensive cleaning and de-scaling of the injection nozzles is no longer required.

During storage conventional sodium hypochlorite losses up to 20 % of its active chlorine. The 1 % sodium hypochlorite generated by EASYCHLORGEN does not require any additives; its chlorine contents remains stable over months.

Process-oriented production, direct storage and dosing of sodium hypochlorite rules out accidental leakage and contact of sodium hypochlorite with the operating personnel.

Easy handling

The operator only needs to fill the salt dissolving container with salt. MINICHLORGEN generates from the saturated brine a diluted brine in the correct concentration which is optimally matched to electrolysis. The diluted brine is guided to the electrolytic cell in which sodium hypochlorite is generated using electric current. This procedure is repeated until the supply tank has been filled.

Lutz-Jesco GmbH provides a wide range of dosing pumps and accessories as well as complete dosing solutions to transport the sodium hypochlorite safely to the process.

Functions

- Chlorine capacities of 240 – 8500 g/h available
- Only use of salt as a chemical
- Eliminate delivery and handling of hazardous chemicals
- Needs-tailored production and storage on-site
- Safe and completely sealed electrolysis procedure
- Considerable health & safety benefit to operators
- Integrated control with OLED screen and simple 3-button operation
- Multilingual operating display
- Telemetry alarm event and data logging option
- No exhaust gases in contrast to conventional sodium hypochlorite solutions in dosing pumps
- Eliminate injection point scaling associated with commercial sodium and calcium hypochlorites
- Easy maintenance and low maintenance frequency
- Remote transfer of the fault message, data logging & RS485 options

Areas of Application

- Chlorination in water works and domestic drinking water supply
- Food washing / processing treatment
- Dairies / Breweries cleaning in place (CIP)
- Cooling tower biocide treatment
- Secondary disinfection
- Industrial chlorination treatments
- Swimming and spa pool disinfection

Technical data

EASYCHLORGEN		240	280	480	560	1100	2200	4250	8500
Chlorine performance*	g/h	240	280	480	560	1100	2200	4250	8500
Chlorine concentration	g/l	5 – 8							
Energy consumption	kWh	1.75	1.4	3.33	2.8	5.6	11	21.25	42.5
Voltage supply		110/240 V, 1ph , 50 Hz				400 V, 3ph , 50 Hz**			
Operating pressure	bar	1.5 – 8.5							
Water consumption	l/h	40	47	80	94	184	367	708	1417
Salt consumption	kg/h	0.72	0.93	1.44	1.85	3.63	7.26	14.02	28.04
Protection class		IP54	IP44	IP54	IP44				
Permissible ambient temperature	°C	5 – 40***							
Permissible feed water temperature	°C	8 – 20****							

* Chlorine capacities from 30, 60 and 90 g/h can be found in the product information "MINICHLORGEN"

** 60 Hz on request

*** in this case, extra venting is required

**** in this case, a water cooler is required

Further specifications upon request

The EASYCHLORGEN is a system for the "in situ" production of the biocide active agent "active chlorine produced from sodium chloride via electrolysis". In accordance with the biocide ordinance, as of 01/09/2015, the member states of the European Union may only use precursors for biocidal active agents produced "in situ" and which are used as disinfectants. These precursors must satisfy the quality requirements made of these substances by DIN EN and be sourced from a manufacturer or supplier listed in accordance with article 95 of the biocide ordinance. Please ask your supplier to confirm conformity with the biocide ordinance (certificate).

Biocidal active agent:

Active chlorine produced from sodium chloride via electrolysis EC no. mix;
CAS no. not applicable

Precursors:

Sodium chloride EC-Nr. 231-598-3;
CAS no. 7647-14-5;
Special salt for electrolytic cells DIN EN 16401 and 14805

Product description

EASYCHLORGEN Compact-Skid (Chlorine capacity 240 or 480 g/h)

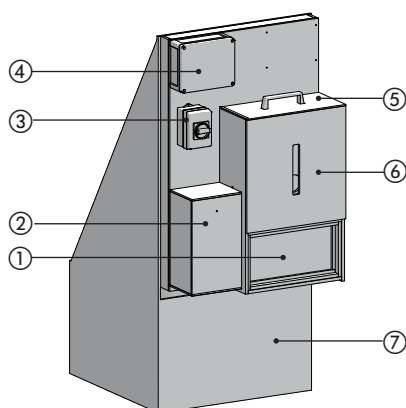

No.	Description
①	Electrolytic cell
②	Water inflow module
③	Main switch
④	Control box
⑤	Salt dissolving container
⑥	Visual salt level indicator and brine saturation chamber
⑦	Floor standing skid and integrated spill containment
without illustration	Hydrogen gas detector and integrated 200 litre product storage tank

Product description

EASYCHLORGEN Standard (Chlorine capacity 280, 560, 1100 or 2200 g/h)

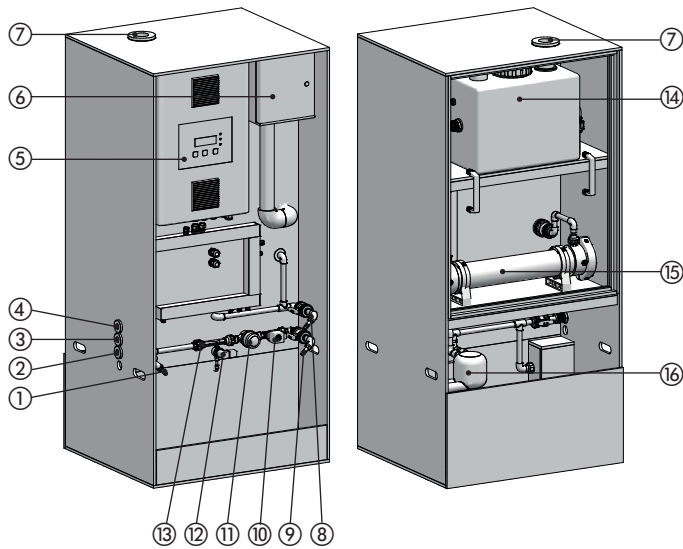

No.	Description
①	Sampler tap for diluted brine
②	Water inflow connection
③	Connection possibility for softened water
④	Product discharge connection
⑤	Control box
⑥	Fan
⑦	H ₂ venting connection
⑧	Product sampling tap
⑨	Softened water sampling tap
⑩	Solenoid valve for water inlet
⑪	Flow meter
⑫	Solenoid valve for brine
⑬	Injector
⑭	De-gassing tank
⑮	Electrolytic cell
⑯	Water softener
without illustration	Hydrogen gas detector

EASYCHLORGEN High Capacity (Chlorine capacity 4250 or 8500 g/h)

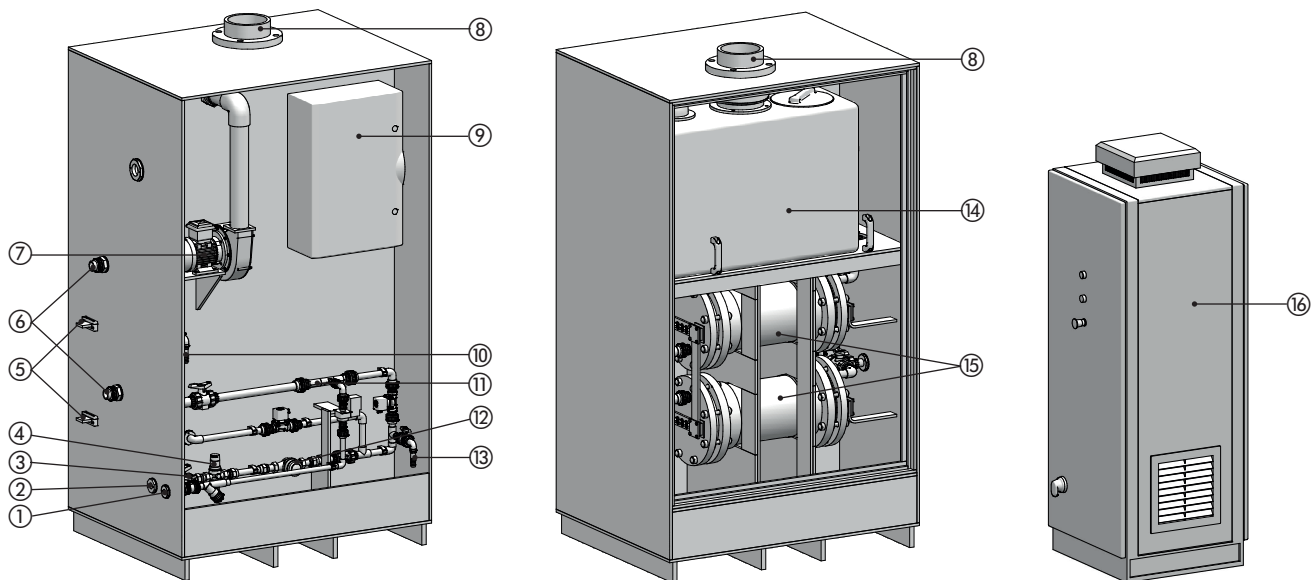

No.	Description
①	Connection for external brine tank
②	Connection for softened water
③	Water inlet
④	Pressure reducer
⑤	Electrical connections for external power supply
⑥	Connection possibility for acidification
⑦	Air blower
⑧	H ₂ venting connection

No.	Description
⑨	Control box
⑩	Sodium hypochlorite sampling tap
⑪	Injector
⑫	Water meter
⑬	Sampler tap for softened water
⑭	De-gassing tank
⑮	Electrolytic cells
⑯	External power supply
without illustration	Hydrogen gas detector

Dimensions

EASYCHLORGEN Compact-Skid (Chlorine capacity 240 or 480 g/h)

All dimensions in mm

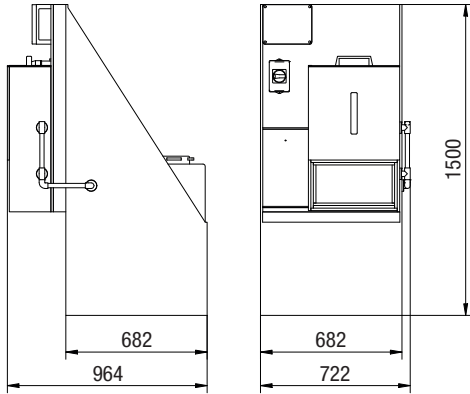

EASYCHLORGEN Standard (Chlorine capacity 280, 560, 1100 or 2200 g/h)

All dimensions in mm

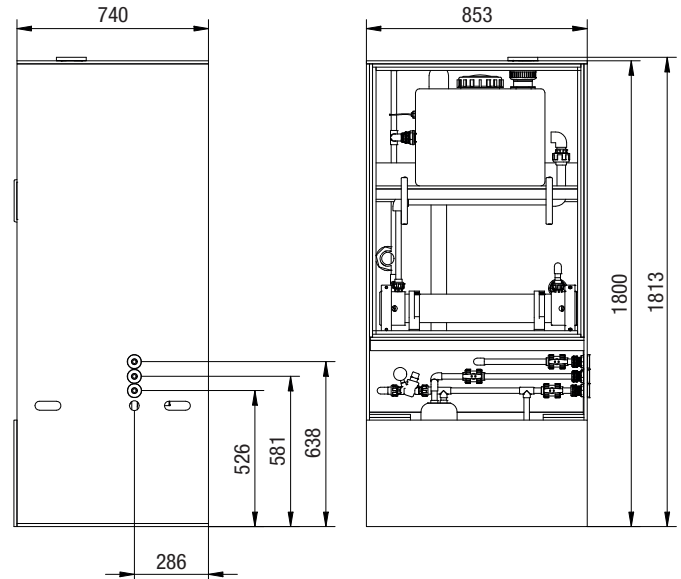

EASYCHLORGEN High Capacity (Chlorine capacity 4250 or 8500 g/h)

All dimensions in mm

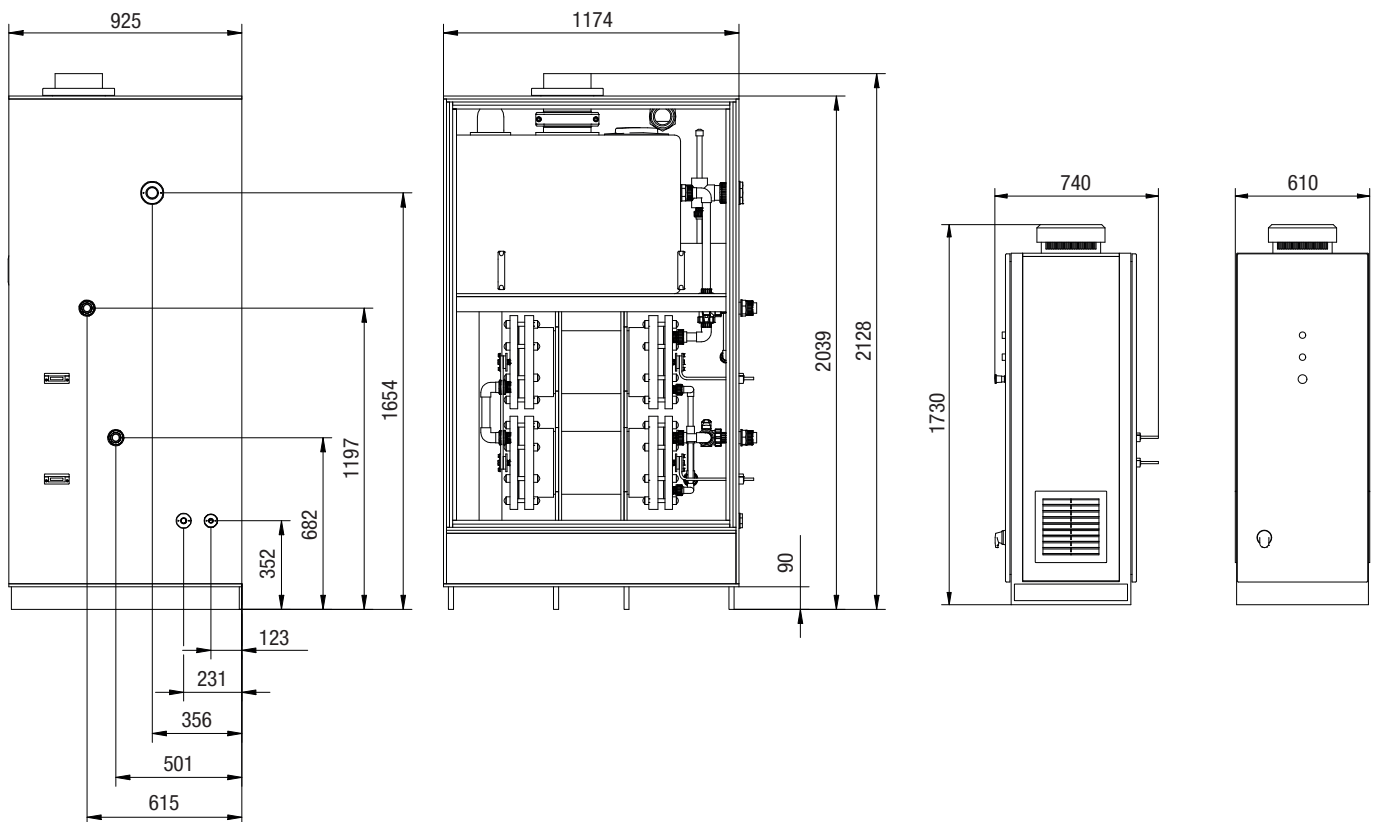

EASYCHLORGEN standard accessories

- Test set for commissioning
- Tanks
- Acidification set
- Modbus interface module