



CHAMPION BRIDGE DRAIN™



MADE IN THE
★ USA ★



Champion Fiberglass is the most advanced manufacturing facility of fiberglass conduit, fiberglass bridge drain and fiberglass strut systems in the world. Its well-trained and highly efficient workforce utilizes state-of-the-art proprietary high-speed winding equipment and high-temperature curing ovens to develop the world's most advanced, highest-quality fiberglass conduit and bridge drain systems. Our 118,000 square-foot facility includes state-of-the-art technology that speeds our output and increases our filament winding capacity rate of manufacture – thereby increasing our ability to delivery quicker, more customized solutions for our customers.

Champion Fiberglass began production of fiberglass conduit (referred to as Reinforced Thermoset Resin Conduit or RTRC in the National Electric Code [NEC]) and fittings in 1988. Since then, Champion Fiberglass has developed into the most advanced manufacturing facility of fiberglass conduit in the world.

In 1989, Champion Fiberglass developed the first fiberglass conduit from an epoxy resin for use above ground. The conduit meets the most stringent industry specifications for flame resistance (UL 94) and smoke generation (ASTM E84). Today, Champion Duct® epoxy conduit is UL and CSA listed for both above (UL 2515, UL 2515A and CSA) and below ground (UL 2420 and CSA) applications. Another milestone was achieved in 2006 when Champion Fiberglass completed development of the first zero-smoke, zero-halogen, two-hour fire-rated Phenolic Conduit System called Flame Shield® – made entirely from non-toxic chemicals. It does not include toxic chemicals such as formaldehyde, etc. Flame Shield has become the conduit of choice for subways, mass transit passenger stations and tunnel two-hour fire-rated applications. Flame Shield meets the requirements of NFPA 130 and NFPA 502.

In 2008, after many years of continuous effort and work with UL and the NEC, Champion Haz Duct® Type XW Conduit was certified for use in Class 1, Division 2 and Zone 1, Division 2 applications per NEC.



Bridge Drain

Champion Bridge Drain™ is a fiberglass bridge drain system that includes a complete line of fittings, non-metallic accessories and hangers. Champion Bridge Drain is a versatile, high-strength fiberglass bridge drainage system that can be used in many highly corrosive drainage applications including bridges, theme parks, aquariums, pools and underground vaults. Run-off waters commonly contain waste materials, heavy metals or hydrocarbon traces. In winter, in some cold regions, they can also contain de-icing salts.

The Champion Bridge Drain is filament wound from corrosion-resistant epoxy resins which enables the bridge drain system to be used in corrosive applications where steel and PVC drainage systems would traditionally fail. Champion Bridge Drain incorporates the highest-quality components to provide superior chemical, UV and fire resistance. Champion Bridge Drain can resist pollutants typically seen in water run-off as well as environmental and climatic stresses. Champion Bridge Drain has a complete network of Sales Representatives and distributors that can provide the necessary assistance.

- **Lightweight** - Champion Fiberglass Bridge Drain features a weight that's up to 1/5 that of comparably sized steel conduit.
- **Lower installation costs** - In addition to lower material costs, Champion Fiberglass Bridge Drain features lower installation costs.
- **Excellent temperature range** - Champion Fiberglass Bridge Drain has an excellent wide temperature range (-60° to +250°), and handles well at low temperatures, allowing for year-round installation. It is also UV-stable.
- **Easier field handling** - Due to its light weight, ease of cutting and integral bell, Champion Fiberglass Bridge Drain is easier to install.
- **High-impact resistance/memory retention** - Champion Fiberglass offers excellent memory retention, with the ability to return to original shape after impact.

Customization Available

Champion Fiberglass Bridge Drain is available in a wide range of sizes - but beyond that, we work closely with our customers to develop custom solutions, from UV-resistant coating specific to your climate and sun exposure or color matching a specific shade needed for your design.

CONTACT US

LET US BUILD IT FOR YOU.

We can easily fabricate custom and specific fittings from your plans - catch basins, hoppers, oval fittings, custom-fit components and odd-degree elbows can all be made to your specifications.

LET'S GET SPECIFIC.

Reach out to us via **ChampionFiberglass.com** or email **info@championfiberglass.com** to discuss your project's needs, run costs, and talk through design, manufacture and delivery logistics. We're here to answer any questions and help make your project a success.



MANUFACTURERS OF
**BRIDGE DRAIN TO
CUSTOMER SPECS**

TM



Features and Advantages

		WEIGHTS PER 100/FT		
		FIBERGLASS	PVC SCH 40	CAST IRON STEEL SCH 40
Champion Fiberglass Bridge Drain™ dramatically reduces bridge dead loads while offering the lowest weight per/ft without sacrificing strength. Weights shown are per/100 ft.	6"	191	373	1,840
	8"	259	562	2,238
	10"	422	797	4,050
	12"	500	1,054	5,110
	14"	683	1,246	6,300
	16"	782	1,628	8,300
	18"	876	2,058	10,500
	20"	1,150	2,418	12,300
	24"	1,513	3,365	17,100
Champion Fiberglass Bridge Drain has an excellent wide temperature range.		-60° to +250°	+40° to +150°	N/A
Champion Fiberglass Bridge Drain has been shown to retain its properties at low temperatures allowing year-round installations.		Excellent	Brittle	Excellent

		BRIDGE DRAIN MATERIAL TYPE SUPPORT SPANS		
		FIBERGLASS	PVC SCH 40	CAST IRON STEEL SCH 40
Many codes require pipe hangers to be spread every 10 ft. regardless of size. Check local codes.	6"	18 ft	7 ft	17 ft
	8"	19 ft	7 ft	19 ft
	10"	21 ft	7 ft	22 ft
	12"	22 ft	10 ft	23 ft
	14"	23 ft	12 ft	25 ft
	16"	24 ft	12 ft	27 ft
	18"	24 ft	12 ft	28 ft
	20"	25 ft	12 ft	30 ft
	24"	26 ft	16 ft	32 ft

	FIBERGLASS	PVC SCH 40	CAST IRON STEEL SCH 40
(Per UL 2515 and CSA C22.2 No. 211.3-96)	Very Good	Poor	Excellent
	200	50	200
Due to its light weight, ease of cutting and integral bell, Champion Fiberglass Bridge Drain™ is very easy to install.	Excellent	Good	Very Poor
Champion Fiberglass Bridge Drain will retain its original shape after impact or compression.	Yes	No	No
	Very Good	Good	Poor unless Galvanized or Stainless
	Very Good	Poor	Poor unless Galvanized or Stainless
	Good	Good	Poor unless Galvanized or Stainless
	Very Good	Good	Poor unless Galvanized or Stainless
	No Painting	Painting	Painting

The corrosion guidelines tests were performed by immersing epoxy coupons for 30 days in the chemical at the temperatures shown. This is a very severe test. It has been shown that Champion Bridge Drain™ can often be used for chemicals listed as “Not Recommended” (NR) as real cases often are limited to fumes, vapors and occasional splashes at the temperatures indicated.

This information is provided solely as a guide since it is impossible to anticipate all individual site conditions. For specific applications which are not covered in this guide, and may require screening tests to evaluate resin system suitability, consultation with Champion Fiberglass is recommended.

UP TO TEMPERATURE, °F	EPOXY CONDUIT		UP TO TEMPERATURE, °F	EPOXY CONDUIT		UP TO TEMPERATURE, °F	EPOXY CONDUIT	
	CHEMICAL	120°		210°	CHEMICAL		120°	210°
Acetaldehyde	N	N	Bromine, liquid	N	N	Dioxane – 1,4	–	–
Acetaldehyde, aq. 40%	N	N	Bromine, gas, 25%	N	N	Dimethylamine	N	N
Acetic Acid, glacial	N	N	Bromine, aq.	N	N	Dimethyl formamide	N	N
Acetic Acid, 20% (25)	R	C	Butane	R	R	Detergents, aq.	R	R
Acetic Acid, 80%	N	N	Butanetriol (erythriol)	–	–	Disbutylphthalate	R	N
Acetic Anhydride	N	N	Butanediol	–	–	Dibutyl sebacate	R	N
Acetone, 10%	N	N	Butyl Acetate	N	N	Dichlorobenzene	N	N
Adipic Acid	C	N	Butyl phenol	N	N	Dichlorethylene	N	N
Alcohol, allyl	N	N	Butyric acid <50%	R	R	Ether (diethyl)	N	N
Alcohol, benzyl	N	N	Calcium salts, aq.	R	R	Ethyl halides	N	N
Alcohol, butyl (n-butanol)	C	N	Calcium hypochlorite	C	N	Ethylene halides	N	N
Alcohol, butyl (2-butanol)	N	N	Calcium hydroxide, 100%	R	R	Ethylene glycol	R	R
Alcohol, ethyl	C	N	Cane sugar liquors	R	N	Ethylene oxide	N	N
Alcohol, hexyl	R	C	Carbon disulfide	N	N	Fatty acids	C	R
Alcohol, isopropyl (2-propanol)	C	N	Carbon dioxide	C	C	Ferric salts	R	R
Alcohol, methyl	N	N	Carbon dioxide, aq.	C	C	Fluorine, gas, dry	N	N
Alcohol, propyl (1-propanol)	R	N	Carbon monoxide	R	C	Fluorine, gas, wet	N	N
Allyl chloride	N	N	Carbon tetrachloride	R	N	Fluoroboric acid, 25%	R	R
Alum	R	C	Casein	R	R	Fluoroboric acid, 10%	C	N
Ammonia, gas	C	N	Castor oil	R	N	Formaldehyde	C	N
Ammonia, liquid	N	N	Caustic potash (KOH)	C	N	Formic acid	C	N
Ammonia, aq. 20%	–	–	Caustic soda (NaOH)	C	N	Freon, F11, F12, 113, 114	N	N
Ammonia salts, except fluoride	R	C	Chlorine, gas, dry	R	C	Freon, F21, F22	N	N
Ammonia fluoride, 25%	R	N	Chlorine, gas, wet	N	N	Fruit Juices and pulps	N	N
Amyl acetate	N	N	Chlorine, liquid	N	N	Fuel oil	R	C
Amyl chloride	R	N	Chlorine, water	C	N	Furfural	N	N
Aniline	N	N	Chloroacetic acid	R	N	Gas, natural, methane	R	N
Aniline hydrochloride	R	N	Chlorobenzene	N	N	Gasoline	N	N
Antimony trichloride	–	–	Chloroform	N	N	Gelatin	R	N
Aqua regia	–	–	Chlorosulfonic acid, 10%	N	N	Glycerine (glycerol)	R	R
Arsenic Acid, 80%	C	N	Chromic acid, 10%	N	N	Glycols	R	C
Aryl-sulfonic acid	R	R	Chromic acid, 30%	N	N	Glycolic acid	C	N
Barium salts	R	C	Chromic acid, 40%	N	N	Green Liquor–paper	R	N
Beer	C	N	Chromic acid, 50%	N	N	Heptane	R	R
Beet sugar liquor	R	N	Citric acid	R	R	Hexane	R	N
Benzaldehyde, 10%	–	–	Coconut oil	R	N	Hydrobromic acid, 25%	C	N
Benzaldehyde, 10–100%	N	N	Copper salts, aq.	R	R	Hydrobromic acid	C	N
Benzene (benzoin)	C	N	Corn oil	R	C	Hydrofluoric acid, 10%	R	N
Benzene sulfonic acid, 10%	R	R	Corn syrup	R	R	Hydrofluoric acid, 60%	N	N
Benzene sulfonic acid, 50%	C	N	Cottonseed oil	R	R	Hydrofluoric acid, 100%	N	N
Benzoic acid	R	R	Cresylic acid, 50%	N	N	Hydrocyanic acid	–	–
Black liquor–paper	R	C	Crude oil	R	R	Hydrogen peroxide, 50%	N	N
Bleach, 12.5% active chlorine	C	N	Cyclohexane	R	N	Hydrogen peroxide, 90%	N	N
Bleach, 5.5% active chlorine	C	N	Cyclohexanol	R	N	Hydrogen sulfide, dry	R	R
Borax	R	R	Cyclohexanone	–	–	Hydrazine	N	N
Boric acid	R	R	Diesel fuels	R	N	Hypochlorous acid, 10%	N	N
Brine	R	N	Diethyl amine	N	N	Jet fuels, JP 4 and JP5	R	N
Bromic acid, <50%	N	N	Diethyl phthalate	R	C	Kerosene	R	N

R = Generally resistant N = Generally not resistant C = Less resistant than "R" but still suitable for some conditions

UP TO TEMPERATURE, °F			UP TO TEMPERATURE, °F			UP TO TEMPERATURE, °F		
EPOXY CONDUIT			EPOXY CONDUIT			EPOXY CONDUIT		
CHEMICAL	120°	210°	CHEMICAL	120°	210°	CHEMICAL	120°	210°
Lauric acid	R	R	Perchloric acid, 10%	R	C	Tannic acid	R	R
Lauryl chloride	R	R	Perchloric acid, 70%	R	C	Tartaric acid	R	R
Lauryl sulfate	R	R	Perchloroethylene	R	C	Tetrachloroethane	C	N
Lead salts	R	R	Petroleum, sour	R	R	Tetrahydrofuran	N	N
Linoleic acid	R	N	Petroleum, refined	R	R	Thionyl chloride	N	N
Linseed oil	R	R	Phenol, 88%	N	N	Thread cutting oil	R	N
Lithium salts	R	R	Phenylcarbinol	N	N	Terpineol	R	R
Lubricating oils	R	N	Phenylhydrazine	N	N	Toluene	C	N
Machine oil	R	N	Phosphoric acid	C	R	Tributyl phosphate	R	N
Magnesium salts	R	R	Phosphorous, yellow	N	N	Tricresyl phosphate	R	N
Maleic acid	R	R	Phosphorous, red	N	N	Trichloroacetic acid	C	C
Manganese sulfate	R	R	Phosphorous trichloride	N	N	Trichloroethylene	N	N
Mercuric salts	R	R	Phthalic acid	R	R	Triethanolamine	R	N
Mercury	R	R	Potassium salts, aq.	R	R	Triethylamine	C	N
Methane	R	R	Potassium permanganate, 25%	C	C	Turpentine	R	N
Methyl acetate	N	N	Propane	R	R	Urea, 50%	R	N
Methyl bromide (gas)	N	N	Propylene dichloride	N	N	Urine	R	N
Methyl cellosolve	-	-	Propylene glycol	R	R	Vaseline	R	R
Methyl chloride	N	N	Propylene oxide	N	N	Vegetable oils	R	R
Methyl chloroform	N	N	Pyridine	N	N	Vinegar	R	R
Methyl cyclohexanone	N	N	Rayon coagulating bath	R	N	Vinyl acetate	N	N
Methyl methacrylate	N	N	Sea water	R	R	Water, distilled	C	N
Methylene bromide	N	N	Salicylic acid	R	N	Water, fresh	R	N
Methylene chloride	N	N	Sewage, residential	C	N	Water, mine	R	N
Methylene iodide	N	N	Silicic acid	R	R	Water, salt	R	N
Milk	R	R	Silicone oil	R	R	Water, tap	R	N
Mineral oil	R	R	Silver salts	R	R	Whiskey	R	N
Molasses	R	N	Soaps	R	R	Wines	R	C
Monochlorozene	N	N	Sodium hydroxide	N	N	Xylene	C	N
Monoethanolamine	N	N	Sodium salts, aq. Except	R	C	Zinc salts	R	R
Motor oil	R	R	Sodium chlorite, 10%	R	N			
Naphtha	R	N	Sodium chlorate	R	R			
Naphthalene	R	R	Sodium dichromate, acid	R	R			
Nickel salts	R	R	Stannic chloride	R	R			
Nitric acid, 0 to 20%	N	N	Stannous chloride	R	R			
Nitric acid, 21 to 100%	N	N	Stearic acid	R	R			
Nitric acid, fuming	N	N	Sulfite liquor	R	C			
Nitrobenzene	N	N	Sulfur	R	N			
Nitrous acid	R	N	Sugars, aq.	R	R			
Oleic acid	R	R	Sulfur dioxide, dry	R	R			
Oleum	N	N	Sulfur dioxide, wet	C	C			
Olive oil	R	R	Sulfur trioxide, gas, dry	R	R			
Oxalic acid	R	R	Sulfur trioxide, gas, wet	N	N			
Ozone, gas, 5%	C	N	Sulfuric acid, < 26%	R	N			
Palmitic acid, 10%	R	R	Sulfuric acid, 26 to 80%	C	N			
Palmitic acid, 70%	R	R	Sulfuric acid, 81 to 100%	N	N			
Paraffin	R	R	Sulfuric acid, 10%	R	N			

R = Generally resistant N = Generally not resistant C = Less resistant than "R" but still suitable for some conditions

- Temperatures represent standard test conditions and are not minimums or maximums. Champion Bridge Drain™ products may be acceptable at other temperatures for some chemicals, but should be tested to determine specific suitability.
- The recommendations or suggestions contained in this table are made without guarantee or representation as to results. We suggest that you evaluate these recommendations and suggestions in your own laboratory or field trial prior to use.



Bridge Drain Specifications

When a standard or other referenced document referred to in this specification is superseded by an approved revision, the revision shall apply.

The Bridge Drain Pipe, also known as Reinforced Thermosetting Resin Piping (RTRP), shall be manufactured **using the single-circuit filament winding process** (up through 12") meeting the requirements of ASTM D 2996 RTRP-12EA12122, with at least 30,000 psi short time rupture strength in the hoop tensile stress. The single-circuit wound conduit shall have a winding angle as close as possible to 54.75°. Multi-circuit winding may be incorporated on 14" and larger sizes of bridge drain straight lengths. Winding mandrels shall be straight and true so as to produce a non-tapered bridge drain pipe. Tapering is allowed at the belled end.

The bridge drain straight lengths resin system shall be epoxy based, with no fillers, using an anhydride curing agent. The fiberglass shall consist of continuous **E-glass Grade "A" roving**. All additives for increasing flame spread and lowering smoke density shall be halogen free, i.e. not contain chlorine or bromine.

Carbon black shall be used as ultraviolet inhibitor to protect the bridge drain and fittings during storage and exposure to the outdoors. Bridge drain, elbows and fabricated fittings shall be concrete-grey in color. UV-resistant exterior coating may be applied (upon customer request) to the finished products to further inhibit UV degradation on pipe exposed to extreme sunlight UV. Upon customer request, bridge drain and fittings shall incorporate an exterior surfacing veil to provide a resin-rich surface that fights corrosion and inhibits UV degradation.

Curing shall be done using an oven and shall take place in two steps. The first curing zone shall bring the bridge drain slowly to the gel temperature. The second zone shall post-cure the bridge drain at no less than 350°F. The bridge drain has to be properly cured so that when measuring the glass transition temperature with a differential calorimeter the difference between the first measurement and the second shall not exceed 5°F.

The internal bridge drain and elbow walls shall be smooth, and all fibers embedded within the epoxy.

All fiberglass bridge drain, fittings and elbows shall be pigmented throughout the wall. Color to be standard concrete-grey unless otherwise specified. Paint or any other exterior coating shall be specified by the customer.

All bridge drain, fittings and elbows shall be durably and legibly marked with the appropriate part number. In addition, the following information shall be included:

- Manufacturer Name
- Date of Manufacturing of Bridge Drain and Fittings
- Special customer markings (per request)

All bridge drain, elbows and fittings shall be **manufactured in the U.S.A. (Spring, TX) and marked as such.**

Bridge drain shall be manufactured having non-tapered sections (except for integral belled ends) and shall be manufactured with following nominal dimensions:

DRAIN PIPE SIZE	OUTSIDE DIAMETER (IN)	INSIDE DIAMETER (IN)	WALL THICKNESS (IN)
4"	4.57"	4.32"	.125"
6"	6.68"	6.43"	.125"
8"	8.48"	8.23"	.125"
10"	10.48"	10.23"	.125"
12"	12.48"	12.23"	.125"
14"	14.48"	14.23"	.125"
16"	16.48"	16.23"	.125"
18"	18.48"	18.23"	.125"
20"	20.56"	20.23"	.165"
24"	24.56"	24.23"	.165"

Tolerances are +.034"/-.028

The bridge drain shall have following mechanical strength when tested in accordance with referenced test method:

Hoop Tensile Strength (based on reinforced thickness @ 75°F)		ANSI/ASTM D-1599
4" through 12"	30,000 psi	
12" through 24"	30,000 psi	
Tensile Strength, Axial	11,000 psi	ASTM D-2105
Ultimate Elongation	2% psi	ASTM D-2105
Modulus of Elasticity (4" conduit)	1.4 x 10 ⁶ psi	ASTM D-2105
Thermal Conductivity	2.0 BTU/(ft ²)(hr)(°F/in)	ASTM D-5930-1
Specific Gravity	1.9	ASTM D-792
Glass Content	65–75%	API 15LR
Water Absorption	1% max	ASTM D-570
Barcol Hardness	52–56	ASTM D-2583
Coefficient of Thermal Expansion	1.2 x 10 ⁻⁵ in/in/°F	ASTM D-696
Compressive Strength (end loads):		ASTM D-2444
Size 4"	23.3 lbs/°F	
6"	36 lbs/°F	
8"	46 lbs/°F	
10"	84 lbs/°F	
12"	99 lbs/°F	
14"	105 lbs/°F	
16"	110 lbs/°F	
18"	123 lbs/°F	
20"	137 lbs/°F	
24"	142 lbs/°F	

Many codes require pipe hanger supports to be spaced every 10 ft. regardless of size. Check local codes.

DRAIN PIPE SIZE	SUPPORT SPAN (FT)
4"	16'
6"	18'
8"	19'
10"	21'
12"	22'
14"	23'
16"	24'
18"	24'
20"	25'
24"	26'

Runs of bridge drain shall be supported at spacing no greater than those on the engineer approved drawings. Steel and fiberglass sling, clamp and clevis hangers designed for hanging and supporting pipes may be used as long as they meet the designated load ratings. Fiberglass bridge/grid hanger-type supports are recommended. If support contains less than 120° of contact, a split fiberglass pipe protective sleeve or fiberglass wear pad shall be installed and bonded to the pipe. Split sleeve length shall equal pipe diameter. This does not apply to bridge/grid-type support hangers.

Pipe strap/clevis hanger width shall be 1-1/2 in. for nominal fiberglass pipe size 6 in. to 10 in. Strap width shall be 2 in. for nominal fiberglass pipe size 12 in. to 14 in. Hanger's thickness shall be 3/16 in. This does not apply to bridge/grid-type hangers.

PIPE STRAP/HANGER WIDTH	
PIPE SIZE (IN)	MINIMUM WIDTH (IN)
4"	1-1/4"
6"	1-1/2"
8"	1-1/2"
10"	1-1/2"
12"	2"
14"	2"
16"	2-1/2"
18"	2-1/2"
20"	3"
24"	3"

All connections between piping systems and roadway drain scuppers shall not be rigid. The deck outlet connection shall be made with a free-floating collector assembly sized 4 in. larger than the outlet pipe. Assemblies shall include an oversized fiberglass splash guard at each collector unit. End run connections should feature a female threaded outlet. Where specifically shown as a clean out, removal pieces shall be made of a threaded PVC plug. The standard plug shall come white in color. Butt or wrap straight section joint connections shall not be allowed. Belled end connections shall be used to connect factory straight lengths. Straight socket slip couplings are acceptable when factory belled ends have been field cut.

UV-resistant epoxy adhesive will be used to bond pipe/fitting connections with straight slip couplings for all joints. All fiberglass pipe, fittings and bonding adhesives shall be provided from the same manufacturer.

Manufacturer shall have a current Certificate, issued by an independent and accredited company, of compliance with an **ISO 9001:2015 Quality Management System**.

The bridge drain shall be supplied with an integral wound bell on one end and a machined spigot on the other end. A two-part adhesive, epoxy resin system, designed to permanently bond fittings and joints of bridge drain shall be properly mixed and applied to the spigot end before joining the bridge drain lengths together. The adhesive shall be available for use in three different ambient temperatures, 70°F, 40°F and 20°F. The adhesive shall be supplied from the same manufacturer of bridge drain, fittings and elbows in order not to void the manufacturer's warranty.

The bridge drain shall not contain any compounds that can release halogens, i.e. chlorine, bromine, fluorine and iodine in more than trace amounts when burning. Following shall be the maximum values when tested in accordance to ASTM E-800:

GASES	VALUES (MAX PPM)
Hydrogen Chloride	0
Hydrogen Bromide	0
Hydrogen Cyanide	<1
Hydrogen Sulfide	0
Ammonia	0
Aldehydes as HCHO	<10
Oxides of Nitrogen	<50

Fiberglass bridge drain, fittings, elbows and accessories shall be manufactured using one of two manufacturing procedures. The first method shall use the same process (filament winding) as is used to manufacture the fiberglass bridge drain straight lengths. The second method shall use a vacuum infusion or resin transfer (RTM) molding process. All elbows shall be manufactured by vacuum infusion or RTM and shall be smooth radius. 90- and 45-degree elbows shall not be mitered. Filament-wound pipe may be used to fabricate mitered tees, laterals, Y's and crosses.

Manufacturer shall have a current Certificate, issued by an independent and accredited company, of compliance with an **ISO 14001:2015 Environmental Management Systems and Performance**.

All fiberglass bridge drain, fittings and elbows shall be handled and installed according to the manufacturer's recommended guidelines and procedures outlined in the catalog.

Material Comparisons – Weights

Fiberglass bridge drain offers the lowest weight and installation costs of any material type bridge drain system. See below weight comparisons for Fiberglass, PVC and Steel bridge drain piping straight lengths.

SIZE	FIBERGLASS		SCH 40 PVC		SCH 40 STEEL	
	WEIGHT PER/FT	WEIGHT FILLED W/ WATER LBS/FT	WEIGHT PER/FT	WEIGHT FILLED W/ WATER LBS/FT	WEIGHT PER/FT	WEIGHT FILLED W/ WATER LBS/FT
4"	1.3	6.8	2.1	7.6	10.8	16.3
6"	1.9	14.4	3.6	16.1	19.0	31.5
8"	2.6	24.2	5.4	27.0	28.5	50.1
10"	4.2	38.3	7.9	42.0	40.5	74.6
12"	5.0	56.0	10.5	61.5	51.1	102.1
14"	6.8	65.3	12.4	70.9	63.0	121.5
16"	7.8	84.3	16.2	92.7	83.0	159.5
18"	8.8	106.0	20.6	117.8	105.0	202.2
20"	11.5	131.9	24.2	144.6	123.0	243.4
24"	15.1	189.3	33.7	207.9	171.0	345.2

Manufacturing Process

Filament winding is a fabrication technique mainly used for manufacturing open tubing or cylinders. This manufacturing process involves winding fiberglass filaments (rovings) under tension over a rotating steel mandrel. Once the epoxy resin has cured in an oven, the steel mandrel is removed or extracted, leaving the finished 20-ft.-long bridge drain section.

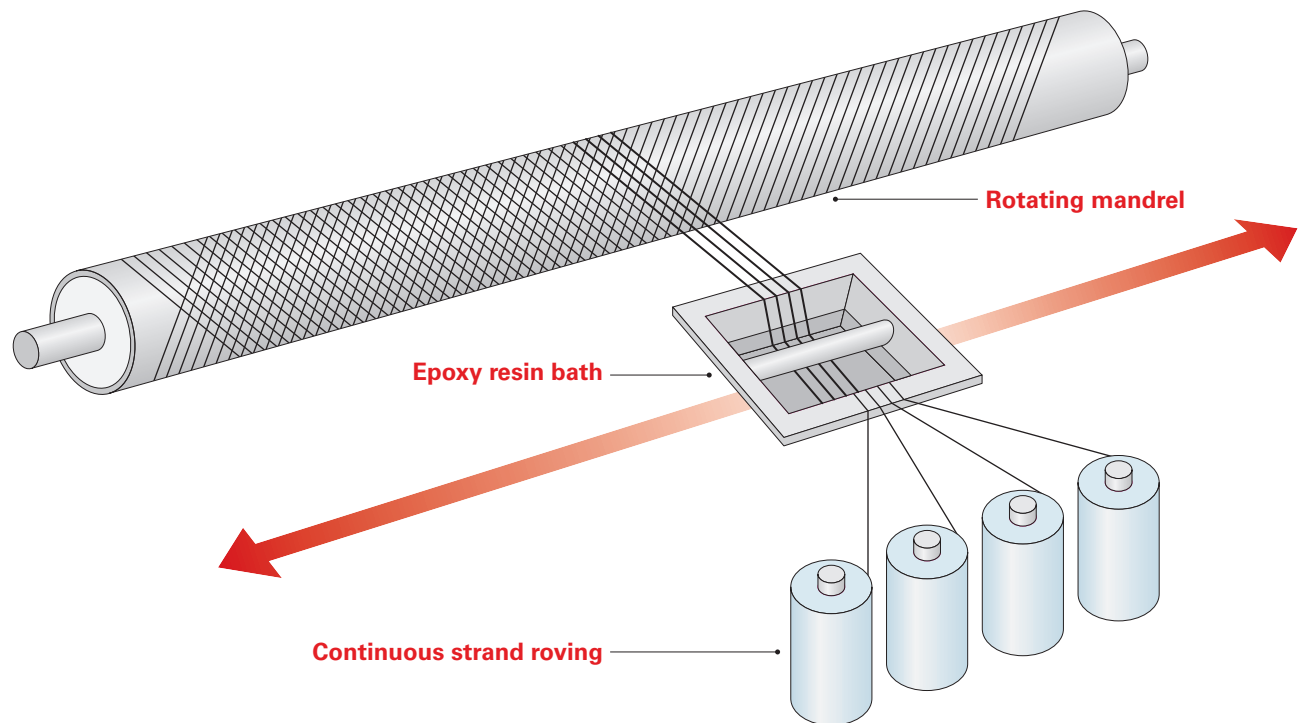

Installation

These instructions are intended only to provide assistance and as a guide to obtain the most appropriate and satisfactory installation of Champion Fiberglass Bridge Drain™ systems.

These instructions are not intended to replace the responsibilities of engineers, customer representatives, owners or other persons responsible in establishing engineering design practices and procedures that are best suited for individual job site conditions.

The installation of fiberglass bridge drain and accessories doesn't differ greatly from the installation of fiberglass conduit and accessories. General installation practices will still apply. The procedures for cutting and sealing can be found below.

Just as with Champion Fiberglass Conduit, Champion Fiberglass Bridge Drain can be installed much faster than traditional steel and PVC bridge drain systems. The lightweight fiberglass components weigh less than half of their steel counterparts and can be cut, drilled and fabricated in much less time than both PVC and steel bridge drain systems. The result is a substantial labor savings.

To make fiberglass bridge drain field cuts, the tools required are a reciprocating saw with an abrasive blade (circular saw) or a grinder with a diamond cutting blade. Marking the fiberglass bridge drain for cutting will require a contrasting colored marker. Remove any cutting/drilling burrs or ridges with 60-grit emery cloth. Factory finished ends are supplied pre-sanded. When field cuts are made, the bridge drain ends need to be sanded in order to make the adhesive connection.



In these cases, it is recommended the ends be sanded with an abrasive flap wheel sander or a grinder with an abrasive sanding disc. Recommended grit is 60-grit emery.



Proper field cutting and sanding PPE to include:

- Long sleeve clothing
- Gloves
- Safety glasses
- Particulate respirator (#N95 or equivalent)

Handling and Storage

Fiberglass bridge drain lengths are shipped in self-supporting crates designed to be unloaded by forklift. Crates should not be dropped from the truck trailer flatbeds.

- **Fiberglass bridge drain** crates should be stored on a flat level surface. The wooden frames should line up so the load will be transferred to the wood frames rather than the bridge drain. The height of stacked bridge drain should be limited to 12 ft.
- **Bridge drain fittings and accessories**, when stored outdoors, should be under cover to protect items in cartons from the outdoor elements until ready for installation.

Bridge Drain Straight Lengths



Champion Bridge Drain straight lengths are made from epoxy resin, supplied in 20-ft. lengths and come factory pre-sanded to allow for quick and easy field assembly. Sizes available range from 4" through 24."

	ITEM NO	NOMINAL SIZE	NOMINAL OD (IN)	NOMINAL ID (IN)	WALL THICKNESS (IN)	WEIGHT PER/FT (LBS)
<input type="checkbox"/>	C-DP-04-20	4"	4.57"	4.32"	.125"	1.3
<input type="checkbox"/>	C-DP-06-20	6"	6.68"	6.43"	.125"	1.9
<input type="checkbox"/>	C-DP-08-20	8"	8.65"	8.40"	.125"	2.6
<input type="checkbox"/>	C-DP-10-20	10"	10.48"	10.23"	.125"	4.2
<input type="checkbox"/>	C-DP-12-20	12"	12.48"	12.23"	.125"	5.0
<input type="checkbox"/>	C-DP-14-20	14"	14.48"	14.23"	.125"	6.8
<input type="checkbox"/>	C-DP-16-20	16"	16.48"	16.23"	.125"	7.8
<input type="checkbox"/>	C-DP-18-20	18"	18.48"	18.23"	.125"	8.8
<input type="checkbox"/>	C-DP-20-20	20"	20.56"	20.23"	.165"	11.5
<input type="checkbox"/>	C-DP-24-20	24"	24.56"	24.23"	.165"	15.1

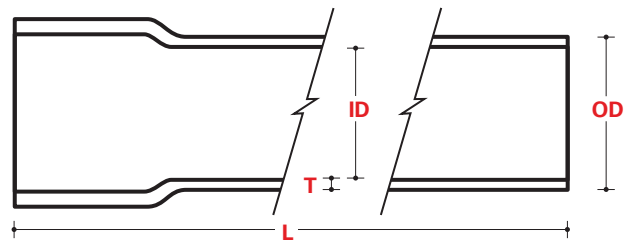

Bridge Drain Fittings

One expansion joint is required for every 200 ft. of straight bridge drain length.

	ITEM NO	NOMINAL SIZE	A DIM (IN)	B DIM (IN)	L DIM MIN (IN)	L DIM MAX (IN)	TRAVEL LENGTH (IN)	WEIGHT (LBS)
<input type="checkbox"/>	C-DF-04-XJ	4"	4.57"	12.0"	21.5"	28.5"	7.0"	6.0
<input type="checkbox"/>	C-DF-06-XJ	6"	6.68"	12.0"	21.5"	28.5"	7.0"	8.0
<input type="checkbox"/>	C-DF-08-XJ	8"	8.93"	12.0"	21.5"	28.5"	7.0"	10.0
<input type="checkbox"/>	C-DF-10-XJ	10"	10.75"	12.0"	21.5"	28.5"	7.0"	12.0
<input type="checkbox"/>	C-DF-12-XJ	12"	12.75"	15.0"	21.5"	31.5"	7.0"	15.0
<input type="checkbox"/>	C-DF-14-XJ	14"	14.40"	15.0"	21.5"	31.5"	7.0"	21.0
<input type="checkbox"/>	C-DF-16-XJ	16"	16.40"	15.0"	21.5"	31.5"	7.0"	27.0
<input type="checkbox"/>	C-DF-18-XJ	18"	18.40"	17.0"	21.5"	33.5"	7.0"	35.0
<input type="checkbox"/>	C-DF-20-XJ	20"	20.60"	17.0"	21.5"	33.5"	7.0"	48.0
<input type="checkbox"/>	C-DF-24-XJ	24"	24.60"	17.0"	21.5"	33.5"	7.0"	60.0

* Add suffix "-F" for fittings to be supplied without bonded fiberglass coupling.

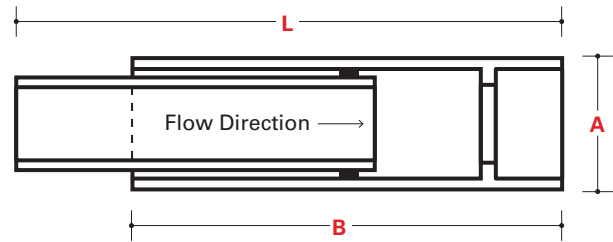

Champion Bridge Drain 90° elbows are vacuum infusion molded, smooth radius elbows. They are available with or without a cleanout.

	ITEM NO	PART NUMBER W/ CLEANOUT	NOMINAL SIZE	A DIM (IN)	X DIM (IN)	R DIM (IN)	WEIGHT (LBS)	WEIGHT W/ CLEANOUT (LBS)
<input type="checkbox"/>	C-DF-04-90-EL	C-DF-04-90-EL-C	4"	10.0"	4.0"	6.0"	2.3	4.5
<input type="checkbox"/>	C-DF-06-90-EL	C-DF-06-90-EL-C	6"	13.0"	4.0"	9.0"	3.4	6.7
<input type="checkbox"/>	C-DF-08-90-EL	C-DF-08-90-EL-C	8"	16.0"	4.0"	12.0"	5.5	10.6
<input type="checkbox"/>	C-DF-10-90-EL	C-DF-10-90-EL-C	10"	19.0"	4.0"	15.0"	8.1	13.2
<input type="checkbox"/>	C-DF-12-90-EL	C-DF-12-90-EL-C	12"	23.0"	5.0"	18.0"	9.7	14.8
<input type="checkbox"/>	C-DF-14-90-EL	C-DF-14-90-EL-C	14"	26.0"	5.0"	21.0"	19.0	24.1
<input type="checkbox"/>	C-DF-16-90-EL	C-DF-16-90-EL-C	16"	29.0"	5.0"	24.0"	23.2	28.3
<input type="checkbox"/>	C-DF-18-90-EL	C-DF-18-90-EL-C	18"	32.0"	5.0"	27.0"	39.8	44.9
<input type="checkbox"/>	C-DF-20-90-EL	C-DF-20-90-EL-C	20"	35.0"	5.0"	30.0"	47.4	52.5
<input type="checkbox"/>	C-DF-24-90-EL	C-DF-24-90-EL-C	24"	41.0"	5.0"	36.0"	56.9	62.0

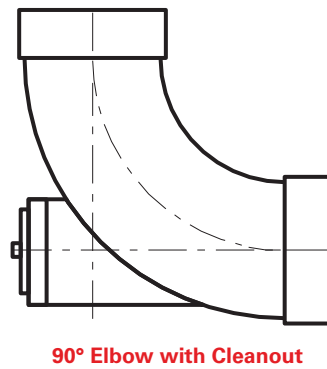
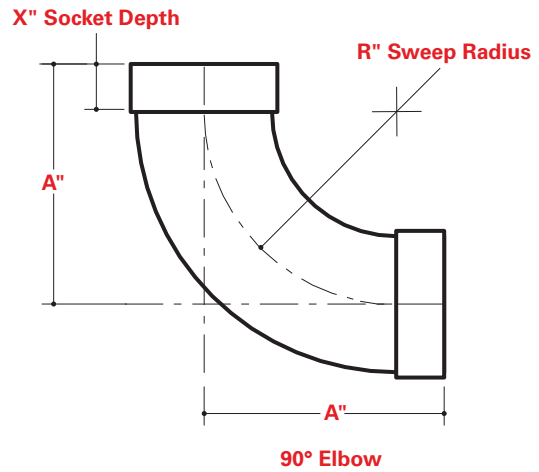

Champion Bridge Drain 45° elbows are vacuum infusion molded, smooth radius elbows. They are available with or without a cleanout.

	ITEM NO	PART NUMBER W/ CLEANOUT	NOMINAL SIZE	A DIM (IN)	X DIM (IN)	R DIM (IN)	WEIGHT (LBS)	WEIGHT W/ CLEANOUT (LBS)
<input type="checkbox"/>	C-DF-04-45-EL	C-DF-04-45-EL-C	4"	6.49"	4.0"	6.0"	2.0	3.8
<input type="checkbox"/>	C-DF-06-45-EL	C-DF-06-45-EL-C	6"	7.73"	4.0"	9.0"	2.3	5.6
<input type="checkbox"/>	C-DF-08-45-EL	C-DF-08-45-EL-C	8"	8.97"	4.0"	12.0"	3.4	8.5
<input type="checkbox"/>	C-DF-10-45-EL	C-DF-10-45-EL-C	10"	10.21"	4.0"	15.0"	4.9	10.0
<input type="checkbox"/>	C-DF-12-45-EL	C-DF-12-45-EL-C	12"	12.46"	5.0"	18.0"	8.8	13.9
<input type="checkbox"/>	C-DF-14-45-EL	C-DF-14-45-EL-C	14"	13.70"	5.0"	21.0"	12.7	17.8
<input type="checkbox"/>	C-DF-16-45-EL	C-DF-16-45-EL-C	16"	14.94"	5.0"	24.0"	15.0	20.1
<input type="checkbox"/>	C-DF-18-45-EL	C-DF-18-45-EL-C	18"	16.18"	5.0"	27.0"	26.4	31.5
<input type="checkbox"/>	C-DF-20-45-EL	C-DF-20-45-EL-C	20"	17.43"	5.0"	30.0"	30.9	36.0
<input type="checkbox"/>	C-DF-24-45-EL	C-DF-24-45-EL-C	24"	19.91"	5.0"	36.0"	37.1	42.2

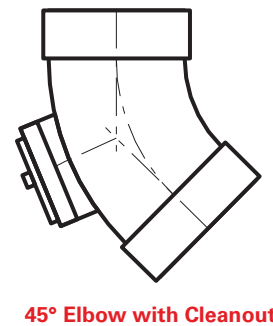
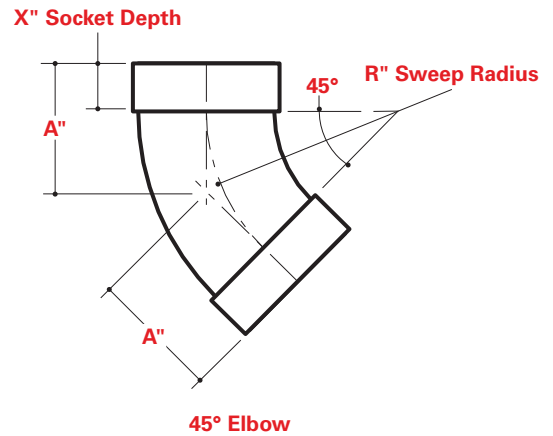

Champion Bridge Drain tees are fabricated from straight lengths and available with a cleanout located in one of three different positions.

	ITEM NO	PART NUMBER W/ CLEANOUT #2	PART NUMBER W/ CLEANOUT #3	NOMINAL SIZE	A DIM (IN)	X DIM (IN)	WEIGHT (LBS)	WEIGHT W/ CLEANOUT (LBS)
<input type="checkbox"/>	C-DF-04-90T	C-DF-04-90T-C2	C-DF-04-90T-C3	4"	9.0"	4.0"	3.5	4.5
<input type="checkbox"/>	C-DF-06-90T	C-DF-06-90T-C2	C-DF-06-90T-C3	6"	12.0"	4.0"	6.0	7.5
<input type="checkbox"/>	C-DF-08-90T	C-DF-08-90T-C2	C-DF-08-90T-C3	8"	15.0"	4.0"	10.4	12.6
<input type="checkbox"/>	C-DF-10-90T	C-DF-10-90T-C2	C-DF-10-90T-C3	10"	18.0"	4.0"	19.0	22.0
<input type="checkbox"/>	C-DF-12-90T	C-DF-12-90T-C2	C-DF-12-90T-C3	12"	21.0"	4.0"	26.0	29.6
<input type="checkbox"/>	C-DF-14-90T	C-DF-14-90T-C2	C-DF-14-90T-C3	14"	25.0"	4.0"	43.0	48.0
<input type="checkbox"/>	C-DF-16-90T	C-DF-16-90T-C2	C-DF-16-90T-C3	16"	28.0"	4.0"	55.0	62.0
<input type="checkbox"/>	C-DF-18-90T	C-DF-18-90T-C2	C-DF-18-90T-C3	18"	32.0"	5.0"	71.0	81.0
<input type="checkbox"/>	C-DF-20-90T	C-DF-20-90T-C2	C-DF-20-90T-C3	20"	35.0"	5.0"	101.0	113.0
<input type="checkbox"/>	C-DF-24-90T	C-DF-24-90T-C2	C-DF-24-90T-C3	24"	41.0"	5.0"	155.0	171.0

* Add suffix "-F" for fittings to be supplied without bonded fiberglass coupling.

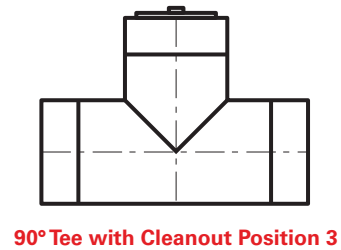
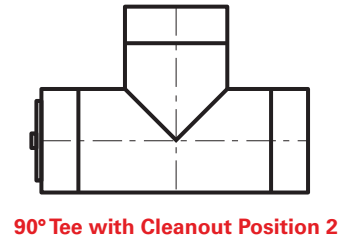
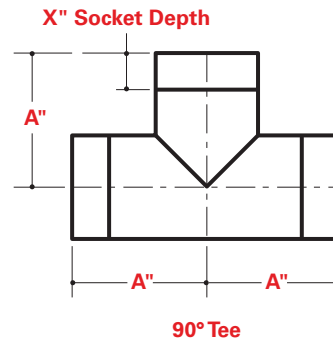

Champion Bridge Drain 45° laterals have a 6" standard cleanout except where noted below:

- 3" cleanout on 4" diameter
- 4" cleanout on 6" diameter

	ITEM NO	PART NUMBER W/ CLEANOUT #2	PART NUMBER W/ CLEANOUT #3	NOMINAL SIZE	X DIM (IN)	A DIM (IN)	B DIM (IN)	WEIGHT (LBS)	WEIGHT W/ CLEANOUT (LBS)
<input type="checkbox"/>	C-DF-04-45-L	C-DF-04-45-L-C2	C-DF-04-45-L-C3	4"	2.0"	9.0"	4.0"	3.0	4.0
<input type="checkbox"/>	C-DF-06-45-L	C-DF-06-45-L-C2	C-DF-06-45-L-C3	6"	3.0"	12.0"	6.0"	6.0	7.5
<input type="checkbox"/>	C-DF-08-45-L	C-DF-08-45-L-C2	C-DF-08-45-L-C3	8"	3.0"	16.0"	7.0"	9.5	11.7
<input type="checkbox"/>	C-DF-10-45-L	C-DF-10-45-L-C2	C-DF-10-45-L-C3	10"	3.0"	19.0"	9.0"	18.0	22.0
<input type="checkbox"/>	C-DF-12-45-L	C-DF-12-45-L-C2	C-DF-12-45-L-C3	12"	3.0"	24.0"	12.0"	27.0	31.0
<input type="checkbox"/>	C-DF-14-45-L	C-DF-14-45-L-C2	C-DF-14-45-L-C3	14"	4.0"	32.0"	16.0"	48.0	54.0
<input type="checkbox"/>	C-DF-16-45-L	C-DF-16-45-L-C2	C-DF-16-45-L-C3	16"	4.0"	36.0"	18.0"	63.0	70.0
<input type="checkbox"/>	C-DF-18-45-L	C-DF-18-45-L-C2	C-DF-18-45-L-C3	18"	5.0"	36.0"	18.0"	71.0	81.0
<input type="checkbox"/>	C-DF-20-45-L	C-DF-20-45-L-C2	C-DF-20-45-L-C3	20"	5.0"	38.0"	18.0"	95.0	108.0
<input type="checkbox"/>	C-DF-24-45-L	C-DF-24-45-L-C2	C-DF-24-45-L-C3	24"	5.0"	42.0"	18.0"	136.0	152.0

* Add suffix "-F" for fittings to be supplied without bonded fiberglass coupling.

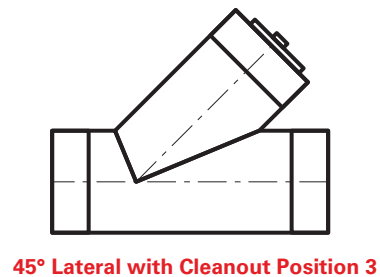
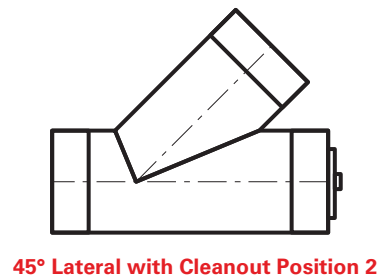
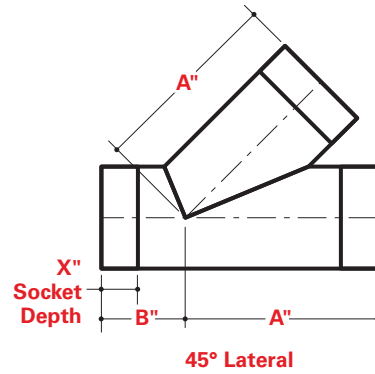

Champion Bridge Drain 45° combination laterals have a 6" standard cleanout except where noted below:

- 3" cleanout on 4" diameter
- 4" cleanout on 6" diameter

	ITEM NO	PART NUMBER W/ CLEANOUT #2	NOMINAL SIZE	X DIM (IN)	A DIM (IN)	B DIM (IN)	C DIM (IN)	D DIM (IN)	WEIGHT (LBS)	WEIGHT W/ CLEANOUT
<input type="checkbox"/>	C-DF-04-45-CL	C-DF-04-45-CL-C2	4"	2.0"	9.0"	4.0"	9.0"	5.0"	6.0	7.0
<input type="checkbox"/>	C-DF-06-45-CL	C-DF-06-45-CL-C2	6"	3.0"	12.0"	6.0"	11.0"	6.5"	7.0	8.5
<input type="checkbox"/>	C-DF-08-45-CL	C-DF-08-45-CL-C2	8"	3.0"	16.0"	7.0"	15.0"	9.5"	11.0	13.5
<input type="checkbox"/>	C-DF-10-45-CL	C-DF-10-45-CL-C2	10"	3.0"	19.0"	9.0"	17.0"	11.5"	16.0	19.1
<input type="checkbox"/>	C-DF-12-45-CL	C-DF-12-45-CL-C2	12"	3.0"	24.0"	12.0"	21.5"	15.0"	34.0	37.6
<input type="checkbox"/>	C-DF-14-45-CL	C-DF-14-45-CL-C2	14"	4.0"	32.0"	16.0"	27.5"	19.5"	46.0	51.7
<input type="checkbox"/>	C-DF-16-45-CL	C-DF-16-45-CL-C2	16"	4.0"	36.0"	18.0"	31.5"	23.0"	60.0	66.5
<input type="checkbox"/>	C-DF-18-45-CL	C-DF-18-45-CL-C2	18"	5.0"	36.0"	18.0"	32.5"	23.5"	72.0	81.4
<input type="checkbox"/>	C-DF-20-45-CL	C-DF-20-45-CL-C2	20"	5.0"	38.0"	18.0"	34.5"	24.0"	90.0	102.1
<input type="checkbox"/>	C-DF-24-45-CL	C-DF-24-45-CL-C2	24"	5.0"	42.0"	18.0"	38.5"	26.5"	130.0	145.7

* Add suffix "-F" for fittings to be supplied without bonded fiberglass coupling.

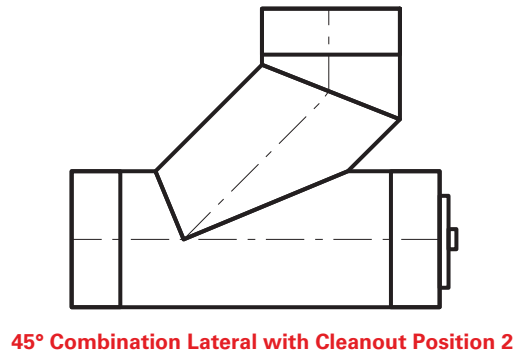
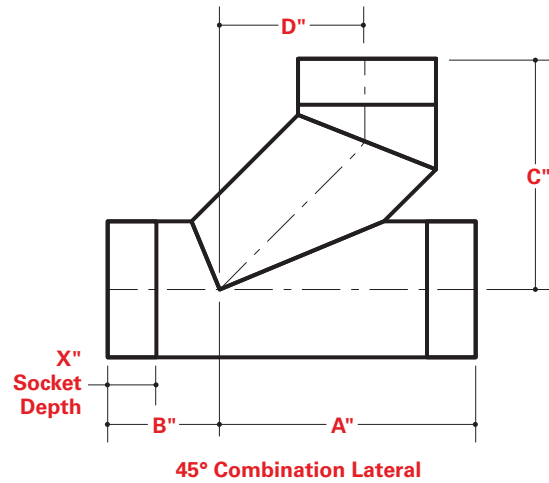

	ITEM NO	NOMINAL SIZE	A DIM (IN)	B DIM (IN)	X DIM (IN)	WEIGHT (LBS)
<input type="checkbox"/>	C-DF-04-45-Y	4"	9.0"	4.0"	6.0"	3.0
<input type="checkbox"/>	C-DF-06-45-Y	6"	12.0"	6.0"	6.0"	7.0
<input type="checkbox"/>	C-DF-08-45-Y	8"	16.0"	7.0"	6.0"	9.0
<input type="checkbox"/>	C-DF-10-45-Y	10"	18.0"	9.0"	6.0"	17.0
<input type="checkbox"/>	C-DF-12-45-Y	12"	19.0"	12.0"	6.0"	23.0
<input type="checkbox"/>	C-DF-14-45-Y	14"	24.0"	16.0"	6.0"	36.0
<input type="checkbox"/>	C-DF-16-45-Y	16"	32.0"	18.0"	6.0"	55.0
<input type="checkbox"/>	C-DF-18-45-Y	18"	36.0"	18.0"	6.0"	66.0
<input type="checkbox"/>	C-DF-20-45-Y	20"	36.0"	18.0"	6.0"	86.0
<input type="checkbox"/>	C-DF-24-45-Y	24"	42.0"	18.0"	6.0"	128.0

* Add suffix "-F" for fittings to be supplied without bonded fiberglass coupling.

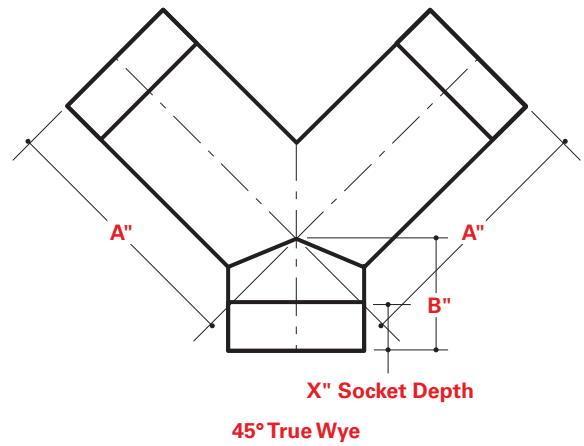

Champion Bridge Drain 45° double laterals have a 6" standard cleanout except where noted below:

- 3" cleanout on 4" diameter
- 4" cleanout on 6" diameter

	ITEM NO	PART NUMBER W/ CLEANOUT	NOMINAL SIZE	X DIM (IN)	A DIM (IN)	B DIM (IN)	WEIGHT (LBS)	WEIGHT W/ CLEANOUT (LBS)
<input type="checkbox"/>	C-DF-04-45-DL	C-DF-04-45-DL-C2	4"	2.0"	9.0"	4.0"	4.0	5.0
<input type="checkbox"/>	C-DF-06-45-DL	C-DF-06-45-DL-C2	6"	3.0"	12.0"	6.0"	7.0	8.5
<input type="checkbox"/>	C-DF-08-45-DL	C-DF-08-45-DL-C2	8"	3.0"	16.0"	7.0"	12.0	14.5
<input type="checkbox"/>	C-DF-10-45-DL	C-DF-10-45-DL-C2	10"	3.0"	19.0"	9.0"	23.0	26.5
<input type="checkbox"/>	C-DF-12-45-DL	C-DF-12-45-DL-C2	12"	3.0"	24.0"	12.0"	35.0	39.0
<input type="checkbox"/>	C-DF-14-45-DL	C-DF-14-45-DL-C2	14"	4.0"	32.0"	16.0"	63.0	69.0
<input type="checkbox"/>	C-DF-16-45-DL	C-DF-16-45-DL-C2	16"	4.0"	36.0"	18.0"	82.0	89.0
<input type="checkbox"/>	C-DF-18-45-DL	C-DF-18-45-DL-C2	18"	5.0"	36.0"	18.0"	93.0	103.0
<input type="checkbox"/>	C-DF-20-45-DL	C-DF-20-45-DL-C2	20"	5.0"	38.0"	18.0"	127.0	139.0
<input type="checkbox"/>	C-DF-24-45-DL	C-DF-24-45-DL-C2	24"	5.0"	42.0"	18.0"	181.0	196.0

* Add suffix "-F" for fittings to be supplied without bonded fiberglass coupling.

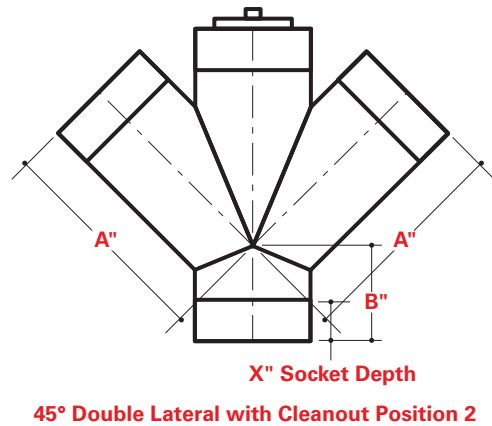
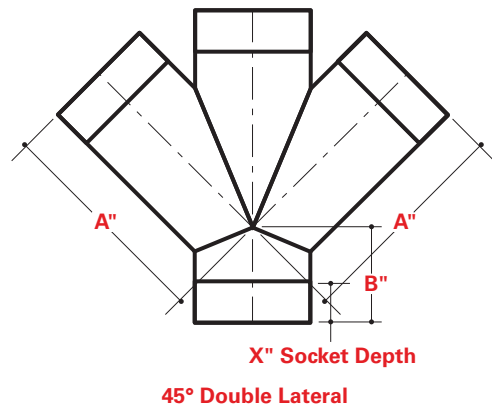

The Champion Bridge Drain 90° cross has a 6" standard cleanout except where noted below:

- 3" cleanout on 4" diameter
- 4" cleanout on 6" diameter

	ITEM NO	PART NUMBER W/ CLEANOUT	NOMINAL SIZE	X DIM (IN)	A DIM (IN)	WEIGHT (LBS)	WEIGHT W/ CLEANOUT (LBS)
<input type="checkbox"/>	C-DF-04-90X	C-DF-04-90X-C	4"	2.0"	8.0"	9.0	11.0
<input type="checkbox"/>	C-DF-06-90X	C-DF-06-90X-C	6"	3.0"	8.0"	13.0	17.0
<input type="checkbox"/>	C-DF-08-90X	C-DF-08-90X-C	8"	3.0"	11.0"	19.0	23.0
<input type="checkbox"/>	C-DF-10-90X	C-DF-10-90X-C	10"	3.0"	13.0"	27.0	33.0
<input type="checkbox"/>	C-DF-12-90X	C-DF-12-90X-C	12"	3.0"	15.0"	38.5	44.0
<input type="checkbox"/>	C-DF-14-90X	C-DF-14-90X-C	14"	4.0"	17.0"	50.0	55.0
<input type="checkbox"/>	C-DF-16-90X	C-DF-16-90X-C	16"	4.0"	18.0"	80.0	85.0
<input type="checkbox"/>	C-DF-18-90X	C-DF-18-90X-C	18"	5.0"	20.0"	110.0	115.0
<input type="checkbox"/>	C-DF-20-90X	C-DF-20-90X-C	20"	5.0"	21.0"	129.0	134.0
<input type="checkbox"/>	C-DF-24-90X	C-DF-24-90X-C	24"	5.0"	23.0"	155.0	160.0

* Add suffix "-F" for fittings to be supplied without bonded fiberglass coupling.

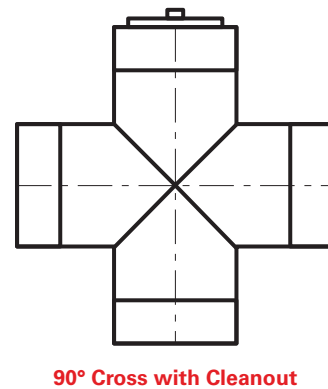
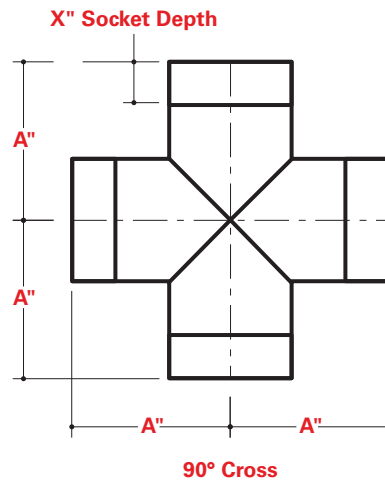

The Champion Bridge Drain 45° cleanout saddle has a 6" standard cleanout except where noted below:

- 3" cleanout on 4" diameter
- 4" cleanout on 6" diameter

	PART NUMBER	NOMINAL SIZE	L DIM (IN)	A DIM (DEG)	WEIGHT (LBS)
<input type="checkbox"/>	C-DF-04-CS-45	4"	10.0"	180°	6.0
<input type="checkbox"/>	C-DF-06-CS-45	6"	10.0"	180°	8.0
<input type="checkbox"/>	C-DF-08-CS-45	8"	14.0"	180°	10.0
<input type="checkbox"/>	C-DF-10-CS-45	10"	14.0"	180°	10.0
<input type="checkbox"/>	C-DF-12-CS-45	12"	14.0"	180°	10.0
<input type="checkbox"/>	C-DF-14-CS-45	14"	14.0"	120°	10.0
<input type="checkbox"/>	C-DF-16-CS-45	16"	14.0"	120°	10.0
<input type="checkbox"/>	C-DF-18-CS-45	18"	14.0"	90°	10.0
<input type="checkbox"/>	C-DF-20-CS-45	20"	14.0"	90°	10.0
<input type="checkbox"/>	C-DF-24-CS-45	24"	14.0"	90°	10.0

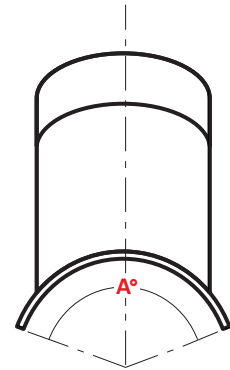
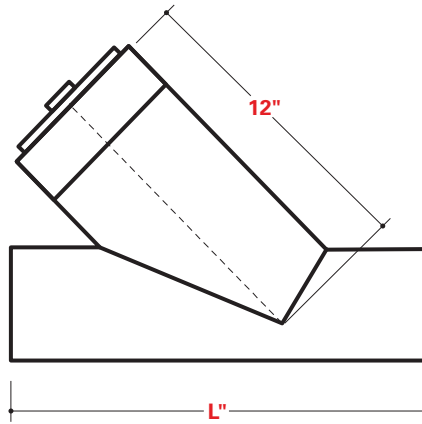

The Champion Bridge Drain 90° cleanout saddle has a 6" standard cleanout except where noted below:

- 3" cleanout on 4" diameter
- 4" cleanout on 6" diameter

	PART NUMBER	NOMINAL SIZE	L DIM (IN)	A DIM (DEG)	WEIGHT (LBS)
<input type="checkbox"/>	C-DF-04-CS-90	4"	10.0"	180°	6.0
<input type="checkbox"/>	C-DF-06-CS-90	6"	10.0"	180°	8.0
<input type="checkbox"/>	C-DF-08-CS-90	8"	14.0"	180°	10.0
<input type="checkbox"/>	C-DF-10-CS-90	10"	14.0"	180°	10.0
<input type="checkbox"/>	C-DF-12-CS-90	12"	14.0"	180°	10.0
<input type="checkbox"/>	C-DF-14-CS-90	14"	14.0"	120°	10.0
<input type="checkbox"/>	C-DF-16-CS-90	16"	14.0"	120°	10.0
<input type="checkbox"/>	C-DF-18-CS-90	18"	14.0"	90°	10.0
<input type="checkbox"/>	C-DF-20-CS-90	20"	14.0"	90°	10.0
<input type="checkbox"/>	C-DF-24-CS-90	24"	14.0"	90°	10.0

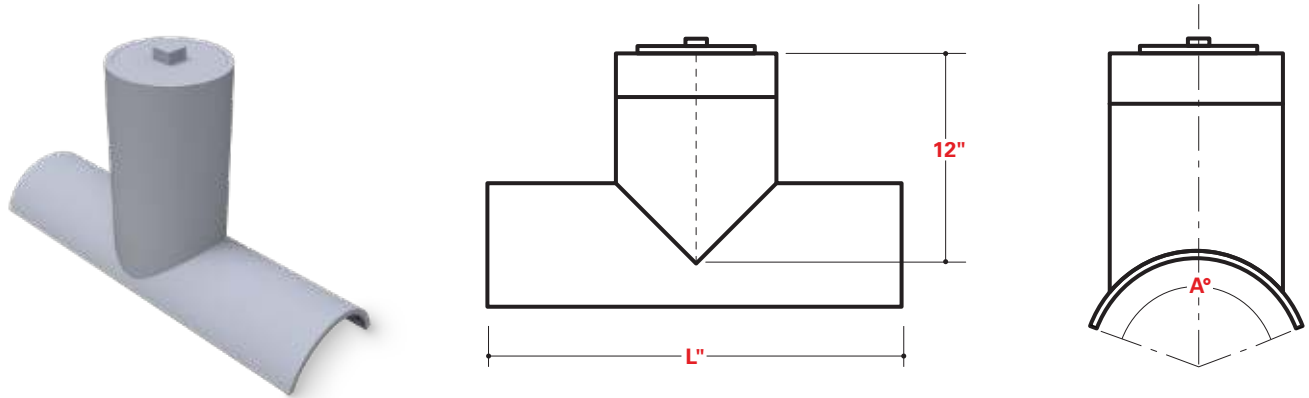

	PART NUMBER	REDUCER SIZE	X DIM (IN)	A DIM (IN)	B DIM (IN)	L DIM (IN)	WEIGHT (LBS)
<input type="checkbox"/>	C-DF-06-04-CR	6" x 4"	3.0"	6.68"	4.57"	12.0"	3.0
<input type="checkbox"/>	C-DF-08-06-CR	8" x 6"	3.0"	8.68"	6.68"	12.0"	4.0
<input type="checkbox"/>	C-DF-10-08-CR	10" x 8"	3.0"	10.75"	8.68"	12.0"	5.0
<input type="checkbox"/>	C-DF-12-10-CR	12" x 10"	3.0"	12.75"	10.75"	12.0"	7.0
<input type="checkbox"/>	C-DF-14-12-CR	14" x 12"	4.0"	14.40"	12.75"	13.0"	8.0
<input type="checkbox"/>	C-DF-16-14-CR	16" x 14"	4.0"	16.40"	14.40"	13.0"	9.0
<input type="checkbox"/>	C-DF-18-16-CR	18" x 16"	5.0"	18.40"	16.40"	14.0"	10.0
<input type="checkbox"/>	C-DF-20-18-CR	20" x 18"	5.0"	20.60"	18.40"	14.0"	13.0
<input type="checkbox"/>	C-DF-24-20-CR	24" x 20"	5.0"	24.60"	20.60"	20.0"	20.0

* Add suffix "-F" for fittings to be supplied without bonded fiberglass coupling.

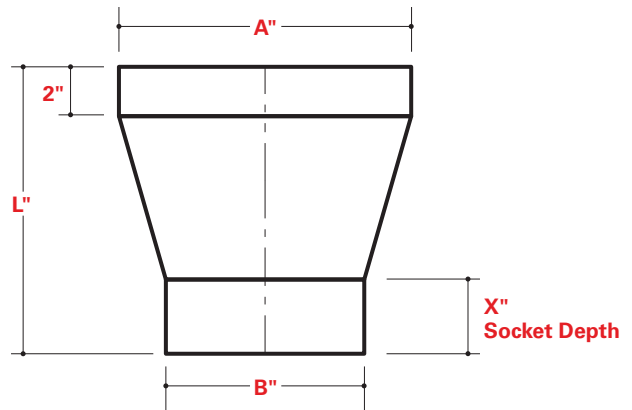

Champion Bridge Drain cleanout end caps insert over the top of the bridge drain straight lengths.

	PART NUMBER	NOMINAL SIZE	X DIM (IN)	A DIM (IN)	OD (IN)	WEIGHT (LBS)
<input type="checkbox"/>	C-DF-04-COE	4"	2.0"	7.0"	4.61"	1.0
<input type="checkbox"/>	C-DF-06-COE	6"	3.0"	7.0"	6.72"	1.5
<input type="checkbox"/>	C-DF-08-COE	8"	3.0"	7.0"	8.68"	2.2
<input type="checkbox"/>	C-DF-10-COE	10"	3.0"	7.0"	10.82"	3.1
<input type="checkbox"/>	C-DF-12-COE	12"	3.0"	7.0"	12.82"	3.6
<input type="checkbox"/>	C-DF-14-COE	14"	4.0"	9.0"	14.82"	5.7
<input type="checkbox"/>	C-DF-16-COE	16"	4.0"	9.0"	16.82"	6.5
<input type="checkbox"/>	C-DF-18-COE	18"	5.0"	11.0"	18.82"	9.4
<input type="checkbox"/>	C-DF-20-COE	20"	5.0"	11.0"	20.90"	12.1
<input type="checkbox"/>	C-DF-24-COE	24"	5.0"	11.0"	24.90"	15.7

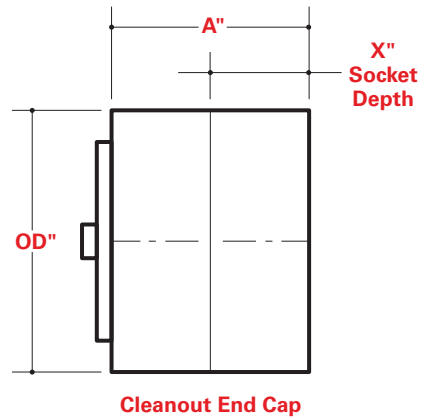

Champion Bridge Drain sleeve couplings are required to connect bridge drain fittings to straight bridge drain lengths or may also be required to connect straight lengths when the belled end has been removed by a field cut or modification.

	PART NUMBER	NOMINAL SIZE	X DIM (IN)	A DIM (IN)	OD (IN)	WEIGHT (LBS)
<input type="checkbox"/>	C-DF-04-CPL	4"	2.0"	7.0"	4.61"	1.0
<input type="checkbox"/>	C-DF-06-CPL	6"	3.0"	7.0"	6.72"	1.5
<input type="checkbox"/>	C-DF-08-CPL	8"	3.0"	7.0"	8.68"	2.0
<input type="checkbox"/>	C-DF-10-CPL	10"	3.0"	7.0"	10.82"	2.5
<input type="checkbox"/>	C-DF-12-CPL	12"	3.0"	7.0"	12.82"	3.0
<input type="checkbox"/>	C-DF-14-CPL	14"	4.0"	9.0"	14.82"	4.0
<input type="checkbox"/>	C-DF-16-CPL	16"	4.0"	9.0"	16.82"	5.0
<input type="checkbox"/>	C-DF-18-CPL	18"	5.0"	11.0"	18.82"	8.0
<input type="checkbox"/>	C-DF-20-CPL	20"	5.0"	11.0"	20.90"	11.0
<input type="checkbox"/>	C-DF-24-CPL	24"	5.0"	11.0"	24.90"	15.0

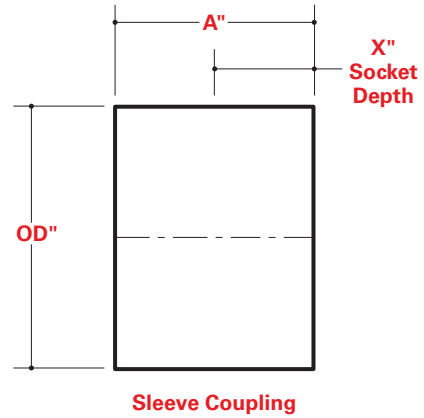

Bridge Drain Adhesives

The CHAMPION MIX system is a two-part adhesive (1-to-1 mix ratio), epoxy resin system, designed to permanently bond fittings and joints of fiberglass reinforced epoxy bridge drain. It is also designed for use with pultruded polyester and vinyl ester components. Each cartridge system contains resin, hardener and one plastic mixer tip. An adhesive gun is required for applying the adhesive (ordered separately). Under normal conditions, it takes approximately 45 minutes for the CM-2040 and CM-2070 adhesives to harden at their rated temperatures. If a faster setting adhesive is desired, there are Champion Mix adhesives available that gel much faster. The "Fast Gel" adhesives can be specified by adding the suffixes, "-FG" or "-SFG" to the item numbers. Because the "Fast Gel" and "Super-Fast Gel" adhesives set up quicker, additional mixing tubes may be required. The epoxy adhesive is also available in three convenient dispensing tube sizes: 50 ML, 80 ML and 300 ML.

	ITEM NO	SIZE	TEMPERATURE RANGE	APPROXIMATE CURING TIME
<input type="checkbox"/>	CM-570	50 ML	70°F (21°C) and above	30–45 minutes
<input type="checkbox"/>	CM-570-FG	50 ML	70°F (21°C) and above	20–30 minutes
<input type="checkbox"/>	CM-570-SFG	50 ML	70°F (21°C) and above	3–7 minutes
<input type="checkbox"/>	CM-540	50 ML	40°–70°F (4°C–21°C)	30–45 minutes
<input type="checkbox"/>	CM-540-FG	50 ML	40°–70°F (4°C–21°C)	20–30 minutes
<input type="checkbox"/>	CM-540-SFG	50 ML	40°–70°F (4°C–21°C)	3–7 minutes
<input type="checkbox"/>	CM-1070	80 ML	70°F (21°C) and above	30–45 minutes
<input type="checkbox"/>	CM-1070-FG	80 ML	70°F (21°C) and above	20–30 minutes
<input type="checkbox"/>	CM-1070-SFG	80 ML	70°F (21°C) and above	3–7 minutes
<input type="checkbox"/>	CM-1040	80 ML	40°–70°F (4°C–21°C)	30–45 minutes
<input type="checkbox"/>	CM-1040-FG	80 ML	40°–70°F (4°C–21°C)	20–30 minutes
<input type="checkbox"/>	CM-1040-SFG	80 ML	40°–70°F (4°C–21°C)	3–7 minutes
<input type="checkbox"/>	CM-2070	300 ML	70°F (21°C) and above	30–45 minutes
<input type="checkbox"/>	CM-2070-FG	300 ML	70°F (21°C) and above	20–30 minutes
<input type="checkbox"/>	CM-2070-SFG	300 ML	70°F (21°C) and above	3–7 minutes
<input type="checkbox"/>	CM-2040	300 ML	40°–70°F (4°C–21°C)	30–45 minutes
<input type="checkbox"/>	CM-2040-FG	300 ML	40°–70°F (4°C–21°C)	20–30 minutes
<input type="checkbox"/>	CM-2040-SFG	300 ML	40°–70°F (4°C–21°C)	3–7 minutes



50 ML Tubes



80 ML Tubes



300 ML Tubes



Champion Fiberglass adhesive guns are available for all three adhesive tube sizes: 50 ML, 80 ML and 300 ML.

	ITEM NO	ADHESIVE TUBE SIZE
<input type="checkbox"/>	CM-AG-5	50 ML
<input type="checkbox"/>	CM-AG-10	150 ML
<input type="checkbox"/>	CM-AG-20	300 ML



CMAG-5



CMAG-8



CMAG-20

Champion Fiberglass 18V Li-Io battery-powered adhesive guns are only available for the 300 ML adhesive tube sizes. This powerful 18V cordless drive system is supplied with a sturdy 300 ML dispensing cartridge carriage.

Other features include:

- Flow control – instant drive disengagement when trigger is released
- Lightweight ergonomic design – reduces wrist and arm strain
- Rapid battery charging – 30 minutes
- Battery fuel gauge – indicates charging power battery level

All battery-powered adhesive guns are supplied fully assembled and supplied with one (1) 18V Li-Io battery and one (1) 18V charger.

	ITEM NO	ADHESIVE TUBE SIZE
<input type="checkbox"/>	CM-AG-20B	300 ML



CMAG-20-B

Champion Fiberglass mixing tips are required for mixing together the two-part epoxy adhesive supplied in tubes. They are available for all three adhesive tube sizes: 50 ML, 80 ML and 300 ML.

	ITEM NO	ADHESIVE TUBE SIZE
<input type="checkbox"/>	CM-MT-5	50 ML
<input type="checkbox"/>	CM-MT-10	150 ML
<input type="checkbox"/>	CM-MT-20	300 ML



Champion Fiberglass Epoxy Adhesive Kit, contains two cans, one with base epoxy adhesive (black color) and the other with hardener (white color), stir sticks, sandpaper for abrading conduit surfaces and an instruction sheet. When properly mixed, the adhesive will be evenly grey. The cans are available in two sizes, 32 oz. and 128 oz.

The adhesive kit is offered for three different ambient curing temperatures:

- 70°F (21°C) ambient temperature
- 40°F (4°C) ambient temperature
- 20°F (-7°C) ambient temperature

	ITEM NO	CAN SIZE (OZ)	TEMPERATURE RANGE (°F)	APPROX CURING TIME (MIN)
<input type="checkbox"/>	CF-3220	32 oz	20°-40°F	30-45 minutes
<input type="checkbox"/>	CF-3240	32 oz	40°-70°F	30-45 minutes
<input type="checkbox"/>	CF-3240-FG	32 oz	40°-70°F	20-30 minutes
<input type="checkbox"/>	CF-3240-SFG	32 oz	40°-70°F	3-7 minutes
<input type="checkbox"/>	CF-3270	32 oz	70°F and above	30-45 minutes
<input type="checkbox"/>	CF-3270-FG	32 oz	70°F and above	20-30 minutes
<input type="checkbox"/>	CF-3270-SFG	32 oz	70°F and above	3-7 minutes
<input type="checkbox"/>	CF-12820	128 oz	20°-40°F	30-45 minutes
<input type="checkbox"/>	CF-12840	128 oz	40°-70°F	30-45 minutes
<input type="checkbox"/>	CF-12840-FG	128 oz	40°-70°F	20-30 minutes
<input type="checkbox"/>	CF-12840-SFG	128 oz	40°-70°F	3-7 minutes
<input type="checkbox"/>	CF-12870	128 oz	70°F and above	30-45 minutes
<input type="checkbox"/>	CF-12870-FG	128 oz	70°F and above	20-30 minutes
<input type="checkbox"/>	CF-12870-SFG	128 oz	70°F and above	3-7 minutes

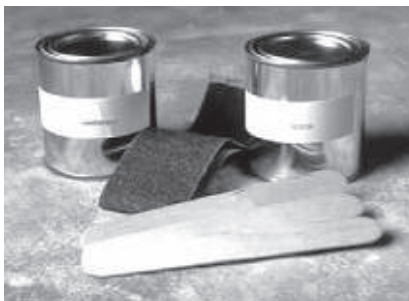

Adhesive curing time is dependent on the ambient temperature. As a guideline, the 70°F adhesive is cured at 75°F (29°C) in 30-45 minutes. Contact Champion Fiberglass for curing information at extreme temperatures (high or low). Champion Fiberglass adhesive can be used for bonding fiberglass and PVC together.

Estimated amounts only for one joint - to determine the amount of adhesive required for a project, multiply the number of ounces required by the number of joints by size - amounts may vary depending on amount of adhesive applied per application.

BRIDGE DRAIN SIZE	ADHESIVE OZ PER JOINT (ML)
4"	4 (118)
6"	6 (177)
8"	8 (236)
10"	10 (295)
12"	12 (354)
14"	14 (414)
16"	16 (473)
18"	18 (532)
20"	20 (591)
24"	24 (710)

The Champion Duct Fiberglass Repair Kit™ includes a strong fiberglass knitted tape, precoated with fast setting water-activated urethane resin.

The Champion Duct Fiberglass Repair Kit™ can be installed by one person with no special tools, and provides for quick, in-field repairs, repairing conduits in as little as 30 minutes.

Routine and Emergency Conduit Repairs Structural Reinforcement
Sealing Joints Rebuilding Conduit side Walls Corrosion Proofing
Abrasion Protection Repairs in Hard to Reach Areas

Petrochemical Industrial processing Pulp and paper Military Marine
Irrigation Power generation Facilities maintenance Water/wastewater
Manufacturing Food processing Pharmaceutical Automotive

- Knitted fiberglass tape with water-activated, fast setting polyurethane resin
- Gloves for easy clean-up
- Detailed instructions



Each kit contains a roll of knitted fiberglass tape precoated with water activated polyurethane resin enclosed in a sealed foil pouch, latex gloves and printed instructions.



Compatibility and Chemical Resistance: The Champion Duct Fiberglass Repair Kit™ combined may be used with any type of fiberglass conduit or piping and is generally compatible with the following classes of chemicals: hydrocarbons, petrochemicals, fuels, organics, acids, bases, water, steam, salts and slurries. The durability of the repair may be affected by very strong acids (pH under 3) or bases (pH over 12).

2 years from date of purchase when stored at 40°F to 83°F (5°C to 28°C).

Black

24,950 psi / in width/172 MPa (ASTM D 3039)

62,505 psi / 4309 MPa (ASTM D 3039)

12,005 psi / 82.77 MPa (ASTM 790)

63 Shore D (ASTM D 2240)

From -20°F up to 250°F (-29°C to 121°C) – continuous.

From 250°F to 500°F (121°C to 260°C) – temporary exposures. If possible, the conduit/pipe should be at ambient temperature before application.

Champion Duct Fiberglass Repair Kit™ is compliant with US DOT 49CFR parts 192 and 195. Testing was performed under the guidelines of ASME PCC-2, Article 4.1.

Tack free in 3 to 5 minutes at ambient temperatures of 50°F to 80°F (10°C to 27°C). Set time is slower below 50°F and faster above 80°F.

Normally cures in 30 minutes at ambient temperatures between 50°F to 80°F (10°C to 27°C). Longer cure times may occur when ambient temperature is less than 50°F (10°C). Heat may be applied to accelerate cure times. Cure time is greatly accelerated at extremely high ambient or pipe surface temperatures. The **UNOPENED** foil pouch may be immersed in cool water for at least 15 minutes to slow set and cure times and to provide ease of handling.

PART NUMBER: BLACK	CHAMPION DUCT FIBERGLASS REPAIR KIT™ SYSTEM SIZE (PACKAGED 10 PER CASE)	WEIGHT LBS/KGS
CF-RK2x4-BLK	2" x 4'/5.08cm x 1.2m	4/1.8
CF-RK2x12-BLK	2" x 12'/5.08cm x 3.6m	6/2.7
CF-RK4x12-BLK	4" x 12'/10.16cm x 3.6m	8/3.6
CF-RK4x25-BLK	4" x 25'/10.16cm x 7.62m	14/6.3

Champion Duct Fiberglass Repair Kit™ does not contain any Volatile Organic Compound (VOC) as defined in the USA for regulatory purposes (ASTM used as a guideline).

Reduced performance to be expected if directions are not explicitly followed!
Follow instructions below specific to the size of conduit/pipe being prepared.

Sand pipe surface with 60-grit emery cloth to remove the gloss finish.

Remove dust by blowing compressed air or rinsing with water.

For best results, prepare an area around the entire conduit/pipe circumference, with a width equal to that of the intended repair.

Put on gloves and make sure gloves are always wet while rubbing & polishing. Follow procedures pictured below.

Allow at least 30 minutes to let Champion Duct Repair Kit™ to cure—for optimal results allow 2 hours.

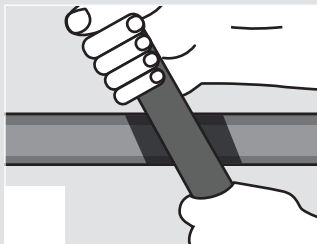

Prepare surface (see above)

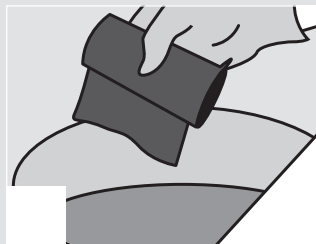

Dip roll for 5 seconds while squeezing 3 times

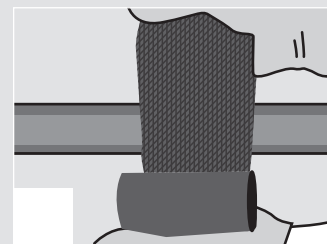

Wrap Champion Duct Repair Kit™ tightly

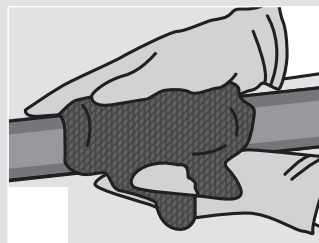

Wet gloves in water and immediately compress the wet expanding resins back into the fiberglass wrap by rapidly and firmly stroking the surface, always in the same direction you wrapped.

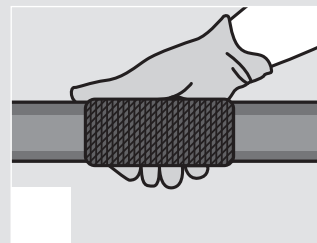

Rub and polish thoroughly. KEEP HANDS MOVING QUICKLY. WET GLOVES FREQUENTLY TO AVOID STICKING. Finished application.

- Read the conduit/pipe preparation instructions first!
- Fully prepare the conduit/pipe surface(s) before opening the first foil pouch.
- Determine the number of kits required before beginning. Contact Champion Fiberglass for assistance if needed.
- Preparedness is the key to a successful installation. Ensure all materials needed are present before you begin.
- When the **Product Selection Guide** (at right) dictates multiple rolls, it is important to apply the rolls in succession one immediately after another. Apply the first roll as per direction but **DO NOT POLISH**. Immediately apply the second and subsequent rolls directly on top of the previous roll.

DO NOT OPEN FOIL POUCHES UNTIL READY TO APPLY EACH INDIVIDUAL ROLL

- When the **Product Selection Guide** (at right) indicates a repair width greater than the tape width (2" or 4"), the product should be applied by spiraling the tape to achieve the desired width. Apply multiple rolls as described above.
- For large diameter pipes or longer lengths requiring multiple roll – more than one installer may be required. Two installers one on each side of the pipe to wrap, one installer for prepping rolls and one installer wetting out the repair would be an example of how to accomplish a large repair.
- Spray large repair areas with a spray bottle while applying Champion Duct Fiberglass Repair Kit™ to keep it wet.
- Resin pouches may be chilled to 50°F before opening to increase working time.

NOMINAL PIPE DIAMETER	2" REPAIR WIDTH*	4" REPAIR WIDTH*	6" REPAIR WIDTH*	8" REPAIR WIDTH*
3/4"	1 (2"x4')	1 (2"x4')	2 (2"x4')	1 (2"x12')
1"	1 (2"x4')	2 (2"x4')	2 (2"x4')	1 (2"x12')
1-1/4"	1 (2"x4')	2 (2"x4')	1 (2"x12')	1 (2"x12')
1-1/2"	1 (2"x4')	2 (2"x4')	1 (2"x12')	1 (2"x12')
2"	1 (2"x4')	1 (2"x12')	1 (2"x12')	1 (4"x12')
2-1/2"	2 (2"x4')	1 (2"x12')	1 (4"x12')	1 (4"x12')
3"	1 (2"x12')	1 (2"x12')	1 (4"x12')	1 (4"x12')
3-1/2"	1 (2"x12')	1 (4"x12')	1 (4"x12')	1 (4"x25')
4"	1 (2"x12')	1 (4"x12')	1 (4"x12')	1 (4"x25')
5"	1 (2"x12')	1 (4"x12')	1 (4"x25')	1 (4"x25')
6"	1 (2"x12')	1 (4"x12')	1 (4"x25')	1 (4"x25')
8"	1 (4"x12')	1 (4"x25')	1 (4"x25')	2 (4"x25')

Note: These are suggestions only. This is a hand-applied product and results may vary depending on the expertise of the applicator. Always apply the entire roll. This information is presented in nominal sizes and actual diameters may vary with the type of pipe and thickness of fittings.

Bridge Drain Hangers

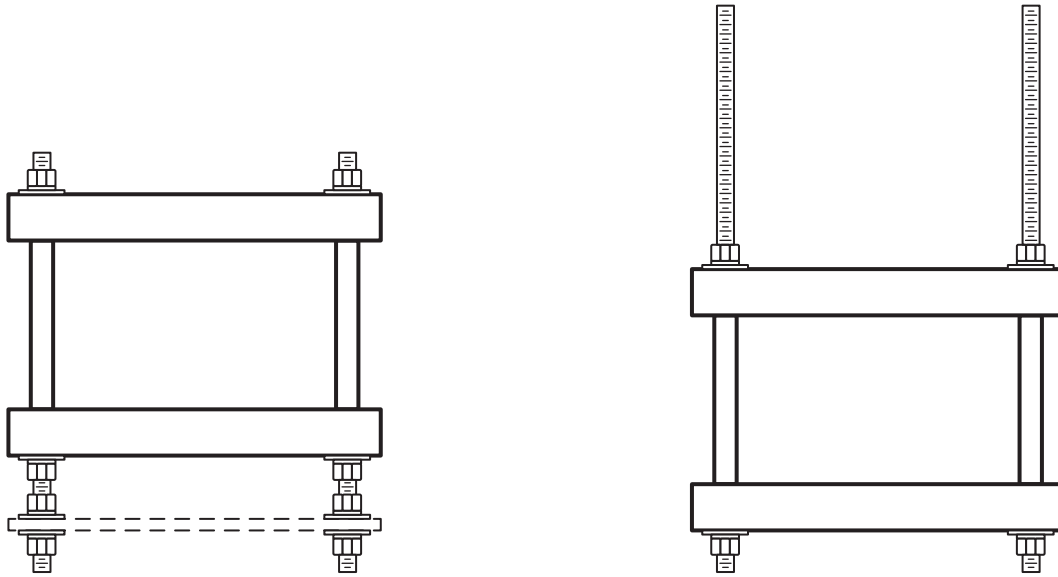

Champion Fiberglass is the leading manufacturer of fiberglass bridge hangers. For over 28 years, our hangers have been recognized for their ability to make your installations easier and more cost-efficient. You'll find them on bridge and DOT applications all over the world and as every bridge application is unique, Champion Fiberglass will work with you to provide specialized designs if needed.

All hangers are constructed from the following grey polyester fiberglass components; special colors are available upon request.

- 1/4" x 2" FRP square tube
- 1/4" x 3" FRP square tube
- 1/4" x 4" FRP square tube
- 1/4" x 2" x 4" rectangular tube
- 1/4" x 3-1/2" x 5-1/2" rectangular tube

Steel Bridge Drain Hanger Rods can be supplied in the following 3/4" diameter options.

- 3/4"-10 HDG
- 3/4"-10-304 stainless steel
- 3/4"-10-316 stainless steel

Domestic steel must be specified if required.

- Champion Fiberglass will provide all information and technical assistance required.
- Fiberglass hangers are recommended for RTRP Bridge Drain to prevent abrasion during expansion/contraction.
- Bridge Hangers can be installed and used with all bridge drain material types.
- Fiberglass Bridge Drain should not be supported directly on or in contact with steel hangers or components.

The Champion Fiberglass Bridge Hanger system consists of two hanger types, Base Mount or Intermediate Hangers.

The Base Mount Hangers are constructed from the same components as the Intermediate Hangers, but are configured to be supported by the structure instead of hanging from the structure.

The Intermediate Hangers are the most widely used “under-bridge” type of conduit and bridge drain support hangers. The Intermediate Hanger consists of a trapeze hanging system comprised of fiberglass flat bar, (and/or) fiberglass square tube and steel threaded rods that are attached to the underside of the bridge. Fiberglass hangers are recommended for RTRP (Reinforced Thermosetting Resin Pipe) bridge drain to prevent abrasion of bridge drain during expansion/contraction.

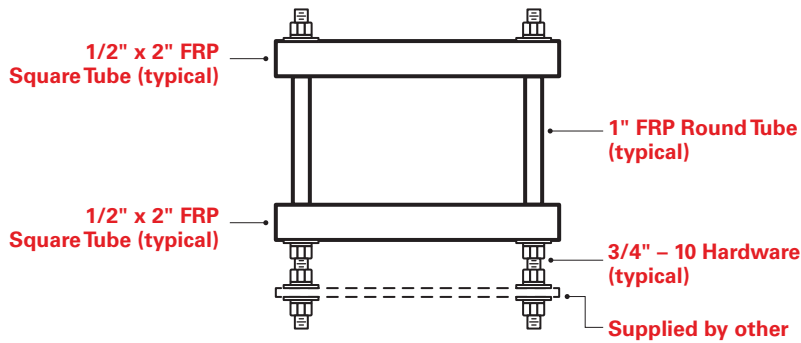

Base Mount Hanger
Square Tube Top and Bottom

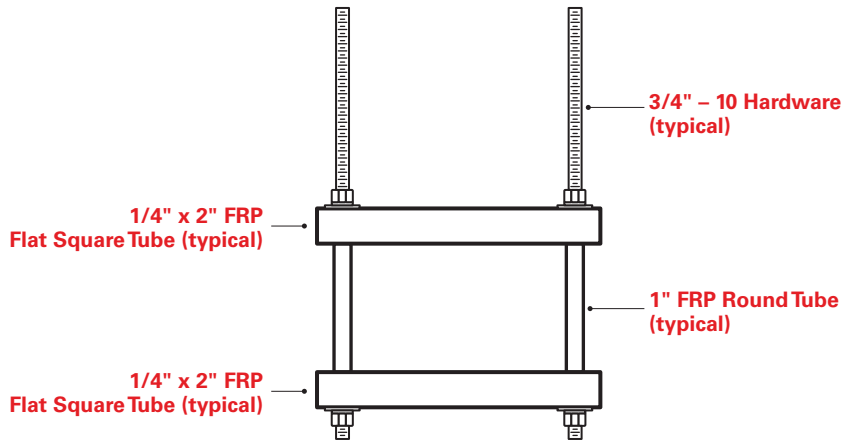

Intermediate Hanger/
Square Tube Top and Bottom

The Anchor Hanger is the same construction as the Intermediate Hanger except that each hanger contains adjustable extending all-thread cross-members that are used to brace the hanger to the bridge structure. Anchor Hangers are recommended every 200 ft. and used with split ring anchors to lock the fiberglass bridge drain into place. Locking the bridge drain into place allows the bridge drain system expansion joints to function as designed.

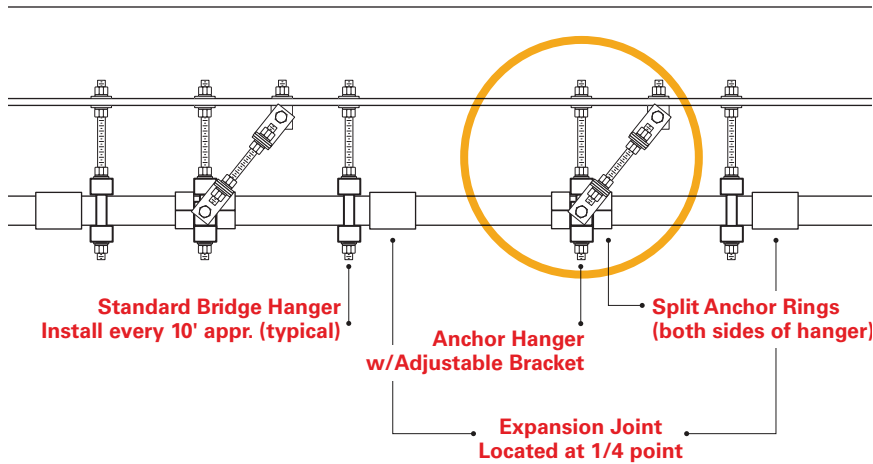

The actual location of the hanger supports should be as close as possible near the quarter point of the span. In a continuous span, the quarter point of the span has the least mechanical stress therefore it is the ideal location for all types of supports. The actual connection of two bridge drain sections is the worst area to install a support. In a continuous span such as bridge drain, this is the area of highest mechanical stress and will cause the most deflection.

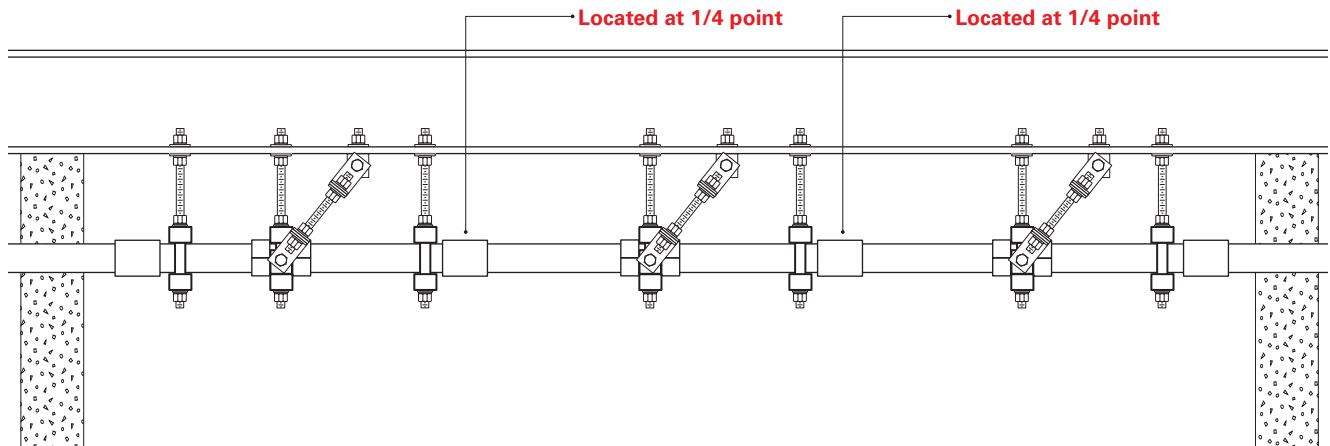

Split Anchor Rings

Split anchor rings are always supplied in pairs and are used for above-ground installations in order to create fixed points. The split anchor rings are placed around the hanger closest to the mid-point between two expansion joints. One pair of split anchor rings is placed on each side of the hanger. The split anchor rings are bonded with epoxy adhesive to the outside of the conduit. The hanger where split anchor rings are used is called an anchor hanger and is normally braced.

	ITEM NO	NOMINAL SIZE	F DIM (IN)	L DIM (IN)	WEIGHT (LBS)
<input type="checkbox"/>	C-DF-04-SR	4"	.25"	3.0"	.5
<input type="checkbox"/>	C-DF-06-SR	6"	.25"	3.0"	.7
<input type="checkbox"/>	C-DF-08-SR	8"	.25"	3.0"	.8
<input type="checkbox"/>	C-DF-10-SR	10"	.25"	3.0"	1.0
<input type="checkbox"/>	C-DF-12-SR	12"	.25"	3.0"	1.3
<input type="checkbox"/>	C-DF-14-SR	14"	.25"	3.0"	1.7
<input type="checkbox"/>	C-DF-16-SR	16"	.25"	3.0"	1.9
<input type="checkbox"/>	C-DF-18-SR	18"	.25"	3.0"	2.2
<input type="checkbox"/>	C-DF-20-SR	20"	.25"	3.0"	2.8
<input type="checkbox"/>	C-DF-24-SR	24"	.25"	3.0"	3.7

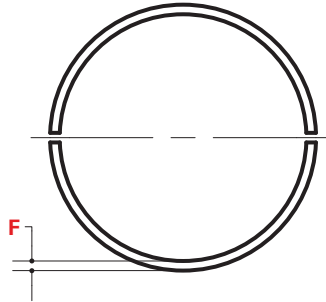
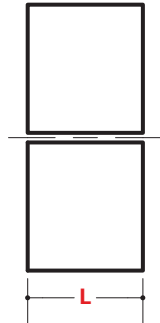



6400 Spring Stuebner Rd
Spring, TX 77389
Main: 281.655.8900
Fax: 281.257.2523
championfiberglass.com

Champion Fiberglass is also a manufacturer of the following products:

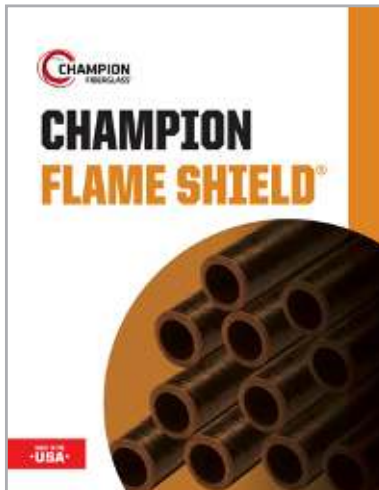

DO MORE.®

© 2022 by Champion Fiberglass, Inc.
All rights reserved. This catalog, or parts thereof, may not be reproduced in any other format without written permission of the publishers.