

PULSAFEEDER®

The Thread Mount Mixer provides a simple means of mounting smaller mixers onto tanks or drums with a bung hole in the cover. Thread mounts feature a 2" nipple which screws directly into a standard bung, cutting labor and cost by eliminating the need for drilling mounting holes or providing additional mixer supports. Thread mount mixers are available with 1/3 HP, 115V, open and 1/20 HP, 115V, TEAO motors. The thread mount holds the mixer securely in a vertical position.

Construction

All mixers feature a 316 stainless steel shaft with an integral impeller. Special epoxy and vinyl shaft coatings are available for applications where the solution being agitated is not compatible with 316 stainless steel. The shaft is coupled to the motor via a brass adapter which is held securely by four stainless steel set screws.

The thread mount adapters are of iron construction and have a corrosion resistant coating.

Installation

Ensure the location of the mixer will allow sufficient clearance between impeller and tank walls. Insert mixer assembly into bung and tighten. Installation is complete.

Features

- 316 SS Shaft
- Epoxy and Vinyl Shaft Coatings Are Available
- Shafts Cut to Length

Operating Benefits

- Thread mount eliminates the need for additional mixer support.
- No need to drill mounting holes.
- Simple Installation.



Aftermarket

- Double Wall Containment Tanks from 15 to 500 gallons.
- 1, 2, or 4 Drum Spill Containment Pallets.
- Metering Pumps.



Thread Mount Mixer

Thread Mount Mixer

Specifications and Model Selection

| Thread Mount Mixer Selection Guide | |
|-----------------------------------------------------------------|----------------------------------------------------------------------------------------------------------------------------------------------------------------------------------------------------------------------------------------------------------------------------------------------------------------------------------------------------------------------------------------------------------------------------------------------------------------------------------------------------------------------------------------------------------------------------------------------------------|
| MOUNT: | T = Thread Mount Mixer |
| HORSEPOWER: | M = 1/20 2 = 1/3 |
| TYPE: | 0 = Open Drip Proof - 1/3 HP only Position 3 thru 4 as needed TE = Totally Enclosed Air Open - 1/20 HP only |
| SHAFT: | H = 316 Stainless Steel |
| AVAILABLE OPTIONS: | WRD = 6' 3 wire 18 gauge SJ cord and plug installed at factory EPOXY = Special epoxy corrosion resistant coating for stainless steel impeller and shaft VINYL = Special vinyl corrosion resistant coating for stainless steel impeller and shaft recommended for sodium hypochlorite 230 = 230V Motor LENGTH = Length in inches represents shaft length requested Suction Tube Shield Assembly. 1" PVC tube, prevents pump suction tubing from entangling with mixer blade. 28655 = 29" - 55 gallon 28656 = 20" - 35 gallon |
| A completed model number should look like 'T-M-TE-H/VINYL, 36"' | |

Engineering Data

1/20 Horsepower

| | |
|-----------------------|--------------------------------------------------|
| RPM: | 1500 |
| Voltage: | 115 V only |
| Amperage: | 1.9 |
| Motor Design: | Split Phase Sleeve Bearings Non Ventilated |
| Shaft Length:* | 28" |

1/3 Horsepower

| | |
|-----------------------|-----------------------------------------------|
| RPM: | 1725 |
| Voltage: | 115 V only |
| Amperage: | 5.9 |
| Motor Design: | Split Phase Ball Bearing Non Ventilated |
| Shaft Length:* | 36" |

* Shafts may be cut to length upon request

Custom Engineered Designs – Pre-Engineered Systems



Pre-Engineered Systems

Pulsafeeder's Pre-Engineered Systems are designed to provide complete chemical feed solutions for all electronic metering applications. From stand alone simplex pH control applications to full-featured, redundant sodium hypochlorite disinfection metering, these rugged fabricated assemblies offer turn-key simplicity and industrial-grade durability. The UV-stabilized, high-grade HDPE frame offers maximum chemical compatibility and structural rigidity. Each system is factory assembled and hydrostatically tested prior to shipment.

Mount Detail

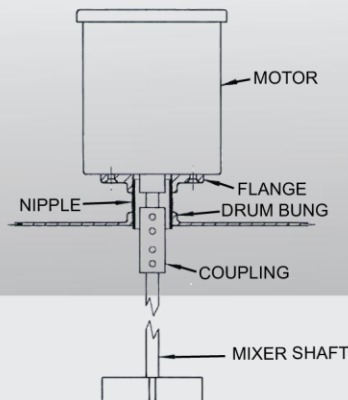

TO 1/3 HP MOTOR MOUNT

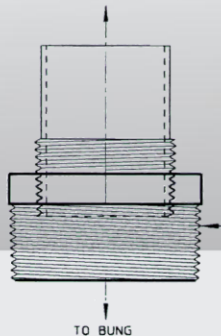

TO 1/20 HP MOTOR BASE

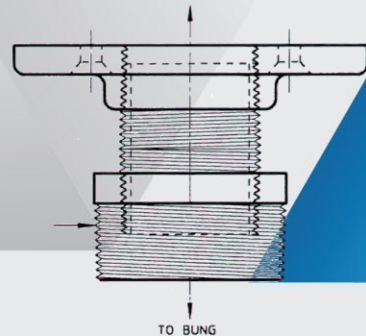

27101 Airport Road
Punta Gorda, FL 33982
Phone: ++1(941) 575-3800
Fax: ++1(941) 575-4085

www.pulsatron.com



An ISO 9001 Certified Company

TMM001 I14

