

INSTALLATION, OPERATION and MAINTENANCE MANUAL

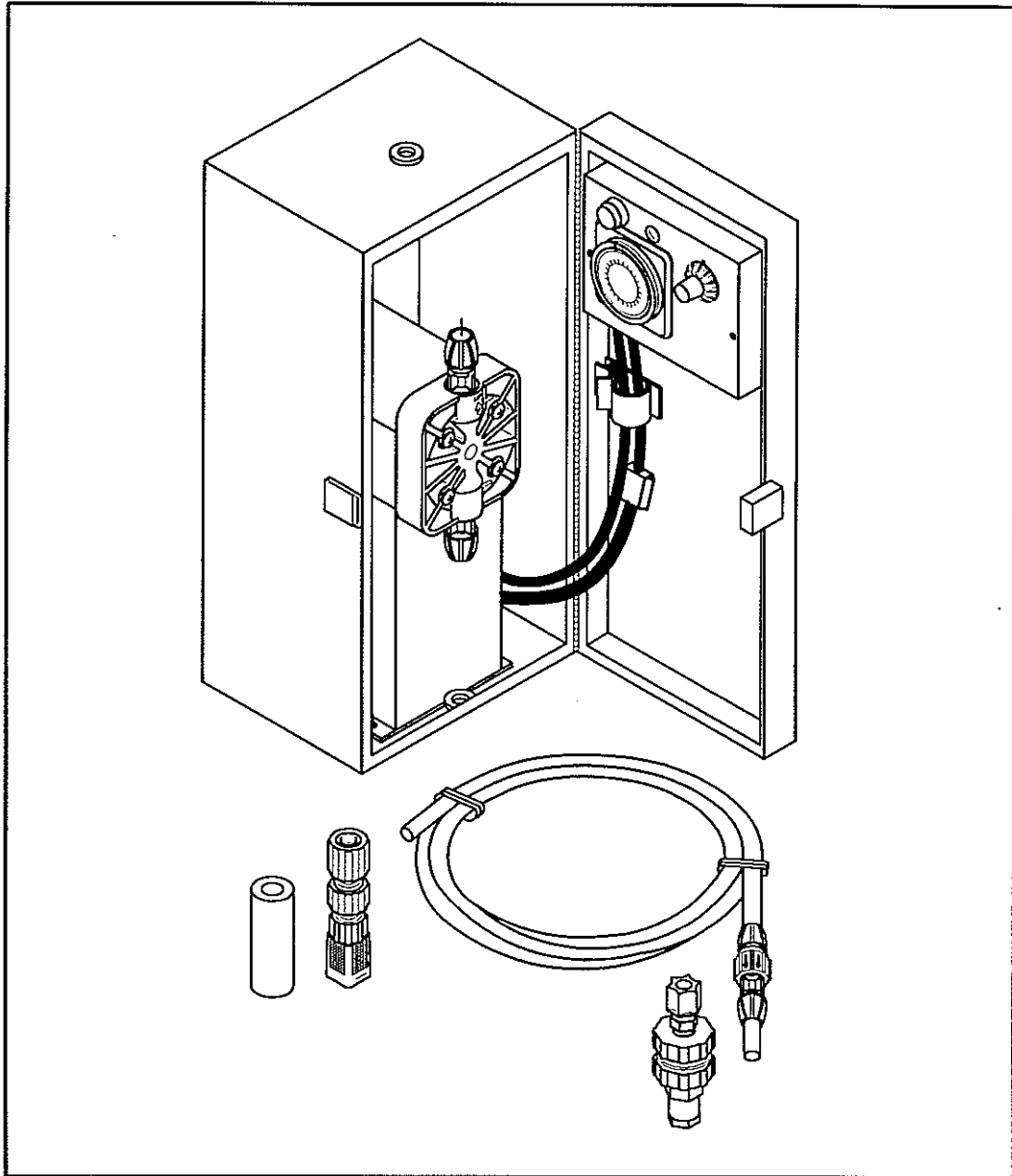

T-2000 SPRAY SYSTEM CHEMICAL SOLUTION FEED PUMP

SPRAY SYSTEM INSTALLATION

1. Select an appropriate location for the Spray System to be mounted via the four mounting holes in the backside of the enclosure.
CAUTION:
 - a) Ensure that the electrical power source is as specified on the data plate.
 - b) Ensure that the timer clock tabs on the control panel are not “depressed”. The Spray System will operate if the tabs are depressed at the ‘time of day mark’ on the clock timer. See ‘AUTOMATIC OPERATION’ for details.

2. Install the spray nozzle bulkhead through the .94-in. diameter hole at the required application site.
 - a) Remove the nut and hard washer from the spray nozzle bulkhead.
 - b) Install the spray nozzle bulkhead through the hole. The spray nozzle end should be toward area to be sprayed. The threaded end of the bulkhead should be protruding through the hole on the other side.
 - c) Place the hard washer back on the threaded end of the bulkhead and secure it with the nut. Tighten nut hand tight.

3. Install discharge tubing and line check to the spray nozzle bulkhead.
 - a) The tubing end that is **closest** to the line check valve is the end that is to be connected to the spray nozzle bulkhead. Connect tubing to the connector on the bulkhead, ensuring that the tubing is “bottomed out” while tightening the compression nut, hand tight only. NOTE: The direction of the ‘arrow’ on the line check valve is pointing in the direction of the spray nozzle bulkhead to verify proper flow direction.

4. Connect discharge tubing to the spray pump.
 - a) Route tubing from the spray nozzle bulkhead to the top of the pump enclosure. Ensure that tubing is clear of other equipment and is supported and free of any kinks. From the top of the pump enclosure an additional 10-inches is required to reach the discharge valve of the pump.
 - b) Cut the tubing. The cut must be straight and square to avoid leaks and for ease of assembly. Do not discard the remaining tubing, this tubing will serve as the suction tubing.
 - c) Route the discharge tubing through the top hole and protective grommet, to the discharge valve of the pump.
 - d) Remove the compression nut from the discharge valve and route tubing through the nut. Connect tubing to the tapered end of the valve body. Ensure that the tubing is securely fitted to the tapered area of the valve, not to exceed a .03-inch gap from the base of the tapered area. Secure tubing to the discharge valve body with the compression nut. Maintain some force on the tubing while tightening the nut to avoid the tubing from slipping during the tightening process. NOTE: If Tubing is difficult to push onto the tapered area of the valve, the end of the tube may be immersed in hot water to ease this procedure.

5. Connect the suction tubing.
 - a) Route the tubing through the hole in the bottom of the enclosure with the protective rubber grommet and ensure that the end of the tube is cut flat and square.
 - b) Remove the compression nut from the suction valve and route tube through the nut. Connect tubing to the tapered end of valve body. Ensure that the tubing is securely fitted to the tapered area of the valve, not to exceed a .03-inch gap from the base of the tapered area. Secure tubing to the suction valve body with the compression nut. Maintain some force on the tubing while tightening the nut to avoid the tubing from slipping during the tightening process. NOTE: If tubing is difficult to push

onto the tapered area of the valve, the end of the tubing may be immersed in hot water to ease this procedure.

- c) Cut the suction tubing to the required length to reach from the suction valve of the pump to the bottom of the chemical container. Be sure the cut is flat and square.
- d) Connect the tubing to the top of the suction strainer. Remove the compression nut from the strainer and route the tubing through the strainer weight and nut. Connect the tubing to the tapered end of the strainer body. Ensure the tubing is fitted securely to the tapered area of the strainer. Secure tubing to the strainer body with the compression nut.
- e) Insert the suction strainer/tube assembly into the chemical container. Ensure that the strainer is submerged to the bottom of the container.

PRIMING

1. Prime the Spray System by depressing the 'GRAY PRIME BUTTON', on the control panel that is located on the door inside the enclosure. The 'GREEN OPERATING LIGHT' should come on. Keep the button depressed until prime is evidenced at the spray nozzle to ensure that the entire system is fully primed prior to automatic operation. At this time check the system for leaks.

AUTOMATIC OPERATION

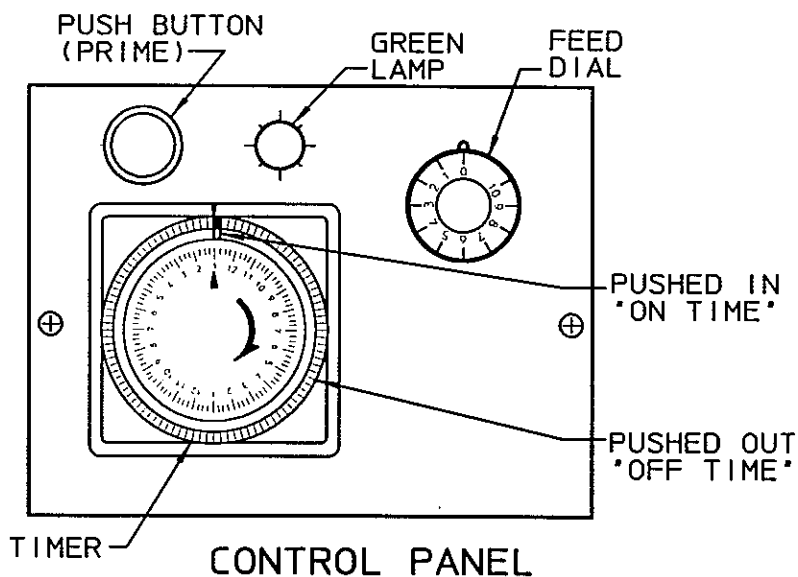

The 24-hour timer has 96 tabs, each of which represents 15-minutes of "ON TIME" if depressed toward the center or "OFF TIME" if not depressed. This will allow for a maximum of 48-settings 30-minutes apart in a 24 hour period. Each "ON TIME" tab must be followed by at least one "OFF TIME" tab to allow the timer to reset.

1. Programming the 24-hour timer.
 - a) Rotate dial clockwise until correct "TIME OF DAY" is aligned with the time of day mark.
 - b) Depress one tab toward the center for each desired activation of the pump. Do not depress two consecutive tabs, the timer requires an "OFF TIME" tab before the pump will reset.
2. Set the feed time dial to desired feed time. Feed time is from 6-seconds at "0" setting, to 600-seconds(10-minutes) at "10" setting. Turn dial clockwise to increase feed time and counterclockwise to decrease feed time. EXAMPLE: A tab pushed in at 1:00AM and a setting of "5" on the feed dial will cause the pump to run for approximately 5-minutes(300-seconds) at 1:00AM and will not allow the pump to run again until the tab at 1:15AM, which would be in the off position, is passed and the next tab in the on position is reached. NOTE: The "FEED TIME" setting is approximate, and the actual required setting should be established by testing for each installation.

T-2000 ASSEMBLY

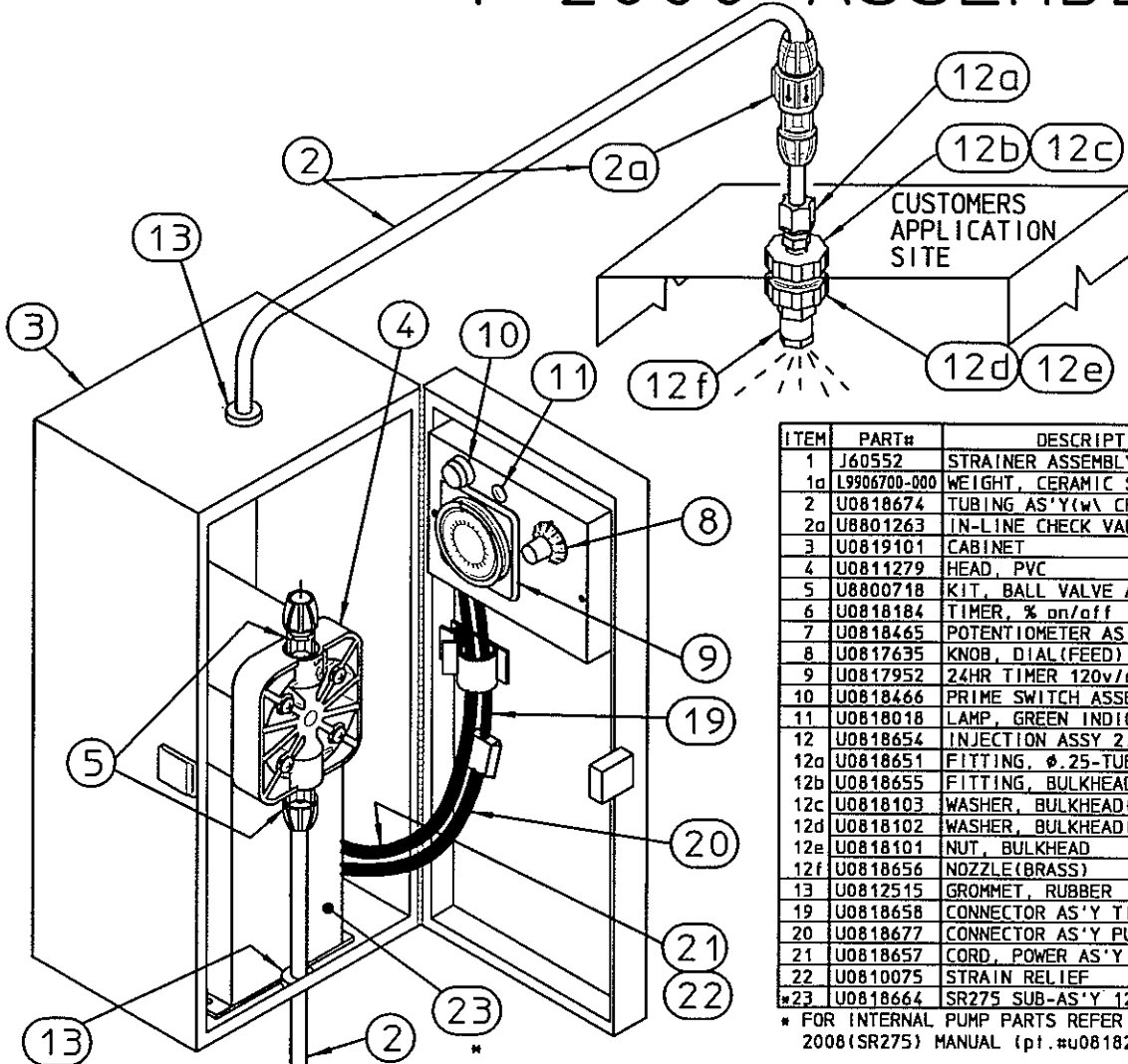

ITEM	PART#	DESCRIPTION	QTY
1	J60552	STRAINER ASSEMBLY w/ WEIGHT	1
1a	L9906700-000	WEIGHT, CERAMIC STRAINER	REF
2	U0818674	TUBING AS'Y (w/ CHECK VALVE)	1
2a	U8801263	IN-LINE CHECK VALVE AS'Y	REF
3	U0819101	CABINET	1
4	U0811279	HEAD, PVC	1
5	U8800718	KIT, BALL VALVE AS'Y .25"	REF
6	U0818184	TIMER, % on/off	1
7	U0818465	POTENTIOMETER AS'Y	1
8	U0817635	KNOB, DIAL (FEED)	1
9	U0817952	24HR TIMER 120v/60Hz	1
10	U0818466	PRIME SWITCH ASSEMBLY	1
11	U0818018	LAMP, GREEN INDICATOR 120v	1
12	U0818654	INJECTION ASSY 2.5cc SPS	REF
12a	U0818651	FITTING, ϕ .25-TUBE x .25-NPT	1
12b	U0818655	FITTING, BULKHEAD	1
12c	U0818103	WASHER, BULKHEAD (RUBBER)	1
12d	U0818102	WASHER, BULKHEAD (PPL)	1
12e	U0818101	NUT, BULKHEAD	1
12f	U0818656	NOZZLE (BRASS)	1
13	U0812515	GROMMET, RUBBER	2
19	U0818658	CONNECTOR AS'Y TIMER (3-PIN-MALE)	1
20	U0818677	CONNECTOR AS'Y PUMP (3-PIN-FEM.)	1
21	U0818657	CORD, POWER AS'Y 115V	1
22	U0810075	STRAIN RELIEF	1
*23	U0818664	SR275 SUB-AS'Y 120/60 T-2000	1

* FOR INTERNAL PUMP PARTS REFER TO STINGRAY 2008 (SR275) MANUAL (pt.#u0818282).

