

# 2400T-DC SERIES INSTALLATION, OPERATION and MAINTENANCE MANUAL

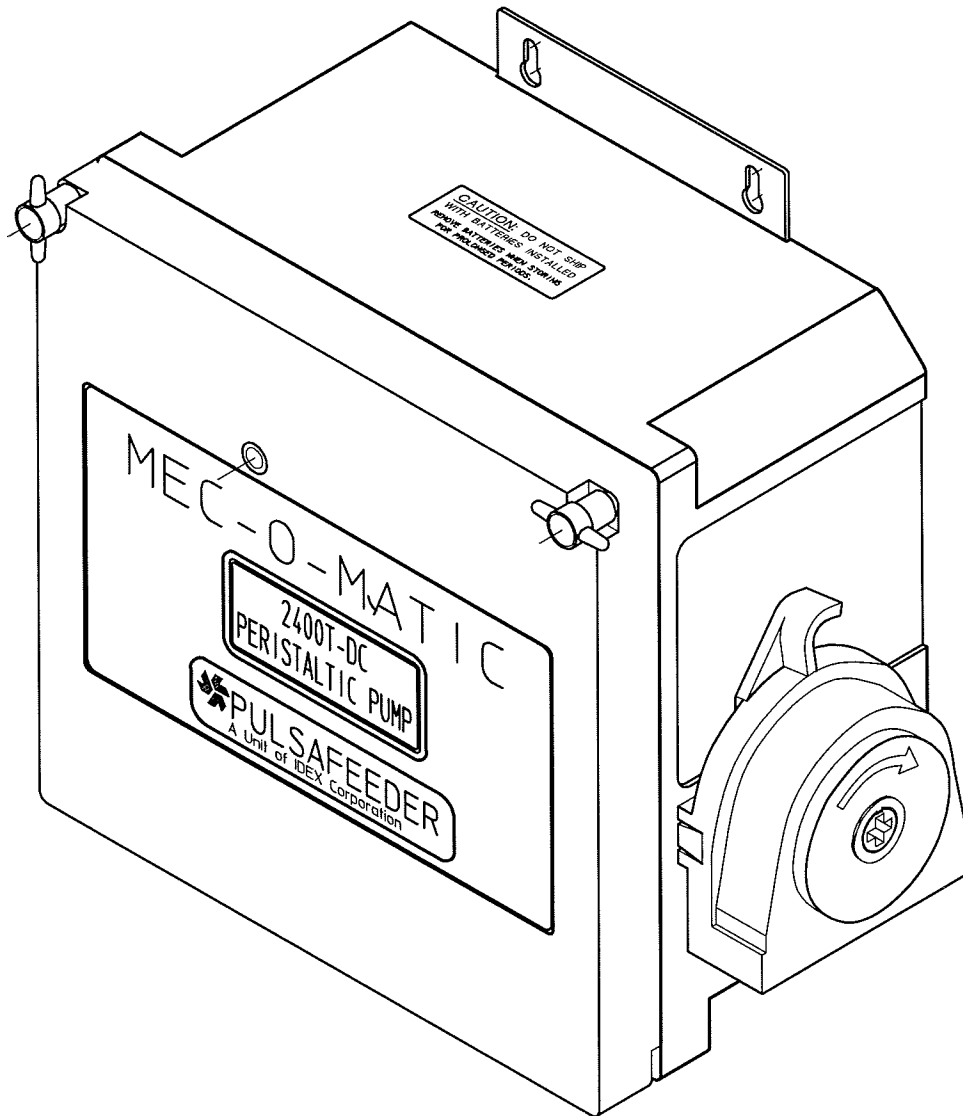

**BATTERY POWERED PERISTALTIC CHEMICAL SOLUTION  
DISPENSER with 24-HOUR DIGITAL TIMER**

**READ ALL WARNINGS CAREFULLY BEFORE  
INSTALLING PUMP**

# TABLE OF CONTENTS

IMPORTANT SAFETY INSTRUCTIONS .....	Page-2
TECHNICAL INFORMATION .....	Page-2 and 12
INSTALLATION .....	Page-3
FIGURE #1, #2 and #3 .....	Page-3
MAINTENANCE .....	Page-4
BATTERIES .....	Page-4
TIMER PROGRAMMING INSTRUCTIONS .....	Page-5, 6 and 7
PROGRAM WORKSHEET and ILLUSTRATIONS .....	Page-8
FIGURE-#4(PARTS LIST and ASSEMBLY) .....	Page-9
FIGURE-#5(PARTS LIST and WET END ASSEMBLY).....	Page-10

---

## IMPORTANT SAFETY INSTRUCTIONS

BEFORE USING YOUR 2400T-DC, BASIC SAFETY PRECAUTIONS SHOULD ALWAYS BE FOLLOWED TO REDUCE THE RISK OF INJURY TO PERSONS.

INCLUDING THE FOLLOWING:

1. READ and UNDERSTAND ALL INSTRUCTIONS
2. FOLLOW ALL WARNINGS and INSTRUCTIONS PRIOR TO USING THIS PRODUCT.
3. THIS PRODUCT SHOULD BE OPERATED ONLY FROM THE TYPE OF POWER SOURCE INDICATED ON THE DATA LABEL.
4. ALWAYS WEAR PROTECTIVE CLOTHING and EYE PROTECTION WHEN FILLING or EMPTYING EQUIPMENT, CHANGING TUBING, WORKING WITH CHEMICALS or JUST WORKING IN THE AREA.
5. USE **CAUTION** WHEN OPERATING or MAINTAINING YOUR EQUIPMENT.
6. ALWAYS KEEP EQUIPMENT and AREA CLEAN FOR PROPER OPERATION and SAFETY.
7. KEEP SAFETY and OPERATION IN MIND WHEN LOCATING PUMP and ROUTING TUBING DURING INSTALLATION or REPAIR. CHECK ALL COMPONENTS TO INSURE THEY ARE PROPERLY LATCHED, SCREWED or TIGHTENED and NOT LOOSE, PINCHED or KINKED.
8. FOLLOW ALL SAFETY and HANDLING INSTRUCTIONS OF THE CHEMICAL MANUFACTURER. USE CHEMICALS or CLEANERS IN ACCORDANCE WITH THE MANUFACTURER'S INSTRUCTIONS.
9. ALWAYS BE AWARE OF DISCHARGE DIRECTION or DESTINATION, KEEP POINTED AWAY FROM OTHER PERSONS and YOURSELF.

---

## TECHNICAL INFORMATION

### FEED RATE:

WITH STANDARD NORPRENE TUBING:

.44in.-O.D. x .25in.-I.D. = 3.0-ounce/minute nominal;

.38in.-O.D. x .19in.-I.D. = 2.0-ounce/minute nominal.

Viton tubing option available.

Overall Dimensions:

8.91in.(22.63cm)-wide, 8.5in.(21.59cm)-tall,

5.19in.(13.18cm)-deep.

### LIST OF STANDARD ACCESSORIES PROVIDED:

Head Tubing,

Self-cleaning Injection Valve Fitting,

.25in.-O.D Polyethylene Tubing(20-ft.),

Manual,

Hose Clamps(qty-2),

Self-adhesive Feet(qty-4),

Mounting Bracket(SST).

### ELECTRICAL RATING.....12vDC,

Premium batteries result in approximately 90-day life at 10-minute/day run time. [(8)-D-Cell Batteries not included].

### MATERIALS:

Pump Head Assembly .....Polycarbonate;

Pump Head Tubing.....Special Norprene Tubing;

Injection Valve Assembly Fitting.....PVC;

Suction/Discharge Tubing.....Polyethylene.

### MAXIMUM SYSTEM PRESSURE 25-PSI(BAR 1.7).

(maximum allowable at injection fitting).

# INSTALLATION

## 1. MOUNTING:

Use key holes on the mounting plate for wall mounting or set the feeder on its 4-rubber feet on a suitable horizontal surface. Feet are not mounted, to mount turn feeder upside down with door closed and stick feet on bottom of pump in four corners (not on door).

## 2. ELECTRICAL:



**WARNING:** READ and FOLLOW ALL INSTRUCTIONS BELOW. SERIOUS INJURY or FIRE COULD RESULT FROM IMPROPER HANDLING. SEE BATTERIES, Page-4.

Use 8-alkaline 'D' batteries to provide 12-vDC power to the pump. Install 4-batteries in each holder as shown in figure-#1.

## PUMP HEAD TUBING INSTALLATION:

3. Rotate the pump head counterclockwise (see Arrows in Figure-#5, Page-10) to disengage from the shoulder screws on the side of pump housing. **DO NOT REMOVE THE SHOULDER LOCK SCREWS.**
4. Grasp the tabs on the back cover of the pump head and pull straight out to remove (see Fig.-#3).



**CAUTION:** DO NOT LOSE THE BEARING FROM THE CENTER HOLE IN THE BACK COVER. It is not necessary to remove the spider and bearings from the head assembly.

5. Remove the old tubing and tube collars from the pump head.

6. Position the spider as shown in Figure-#2. Put tube collars in pump head with open end of collars facing outward. Locate tubing into right collar so ends will be approximately the same length.
7. While rotating the spider counterclockwise (↺), push the tubing into the housing and center over the rollers as shown in Figure-#2.
8. Replace the back cover on the pump head. **BE SURE IT FITS TIGHTLY AGAINST and FLUSH WITH THE PUMP HEAD FRONT.**
9. Slide the pump head onto the motor drive shaft and turn it clockwise to lock onto the 2-shoulder screws. **DO NOT REMOVE THE SHOULDER SCREWS.**
10. Push the suction tubing and discharge tubing into the pump head tubing (See Figure-#5, page-10). **NOTE: DO NOT PUSH SUCTION or DISCHARGE TUBING PAST TUBE COLLARS IN HEAD.** Install hose clamps to hold the tubing together, keep suction clamp within .25in. (.63cm) of head. Use pliers to squeeze clamps tightly.

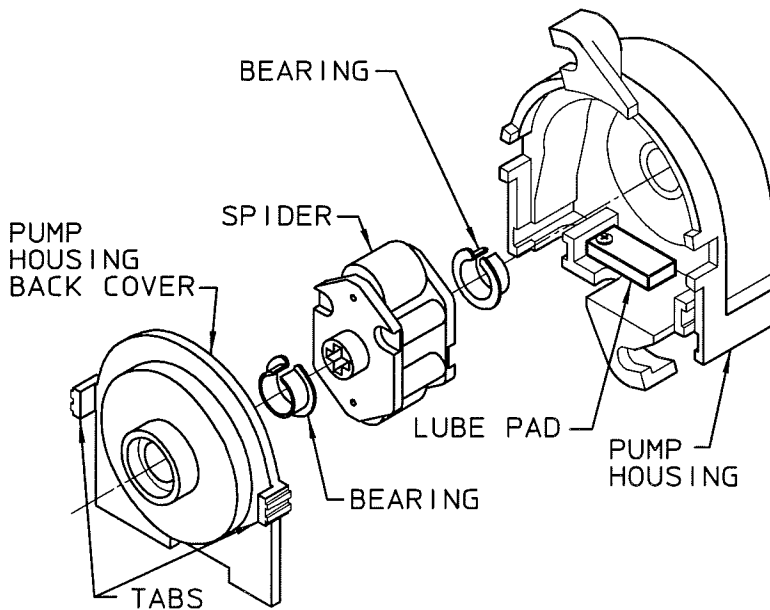

FIGURE #3

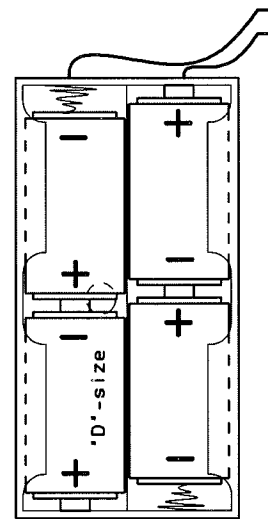

FIGURE #1

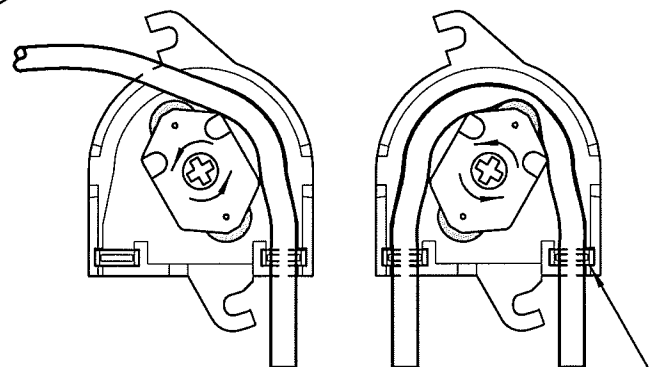

FIGURE #2

TUBE COLLAR

## INSTALLATION(continued)

### 11. INJECTION FITTING:

Install the injection fitting as shown(See Figure-#5, page-10). DO NOT INSTALL IN 'DEAD END' PIPES, or INTO DEEPLY RECESSED TEE'S. The tip of the injection fitting must not extend beyond the center line of the pipe.

- a) Take precautions to prevent loss of fluid from system piping.
- b) The injection fitting has .25in.-NPT(male pipe threads). If needed, drill a .44in.(1.11cm)-Dia. hole and tap for .25-NPT. DO NOT TAP TOO DEEPLY TO INSURE THE INJECTION FITTING WILL FIT TIGHTLY.
- c) Apply Teflon tape to the injection fitting threads. DO NOT REMOVE THE PLASTIC SLEEVE ON THE TIP OF THE FITTING. It is a functional part. Turn the fitting in and tighten.

**CAUTION**: Inspect the plumbing system and eliminate piping cross-connections to prevent feeding of chemical to pipes or fixtures where it's not wanted or needed.

### 12. SUCTION and DISCHARGE TUBING:

Take the 20-ft.(6.1m) length of .25in.(.63cm)-OD tubing(PE) included, measure and cut the lengths needed to run from pump head to the injection fitting and to the chemical tank(See Figure-#5, page-10). Cut the tubing ends square for proper fitting engagement. NOTE: If not using strainer, suction tubing end in container should be cut at an angle to allow unobstructed flow.

### 13. CONNECT DISCHARGE TUBING TO THE INJECTION FITTING-

Remove the injection fitting coupling nut and slide it over the end of the tubing. Push the end of the tubing onto the injection fitting. Slide the nut on and tighten it firmly, by hand only. NOTE: To soften the end of the tubing for easier assembly, immerse in hot water.

**WARNING**: READ IMPORTANT SAFETY INSTRUCTIONS ON Page-#2 BEFORE STARTING ANY MAINTENANCE PROCEDURE.

**CHEMICAL TANK-** To avoid running out of chemical, follow a maintenance schedule to insure adequate supply.

**TUBING INSPECTION-** Inspect all tubing regularly and replace it if deteriorating.

## MAINTENANCE

### REPLACING PUMP HEAD TUBING:

1. Relieve all pressure from the discharge tubing and point of injection.
2. Remove the hose clamps from the tubing at The pump head(twist clamp to disengage teeth).
3. Pull the suction and discharge tubing from the pump head tubing.
4. Refer to installation steps 3 thru 10(Page-#3) to install the pump head tubing.

## BATTERIES

**WARNING**: SERIOUS INJURY or FIRE COULD RESULT FROM IMPROPER HANDLING OF BATTERIES. READ and FOLLOW ALL INSTRUCTIONS BELOW.

1. Use only the size and type of batteries recommended in this manual.
2. Handle batteries with caution so not to short batteries with conductive materials, jewelry, keys, etc., which may cause conductor to overheat and cause burns.
3. Install batteries as indicted(See Fig.-#1) and as shown on battery holders. Improper polarity may cause leaking and/or explosion.
4. Replace all batteries at the same time. Using old and new batteries could cause batteries to overheat and explode.
5. Remove batteries from product if it will not be used for several months to avoid damage by leaking batteries.
6. Do not dispose of used batteries in heat or fire, the batteries may explode. Check local codes for special disposal instructions.
7. Do not open or mutilate the batteries. Internal electrolyte is corrosive to eyes, skin and may be toxic if swallowed.
8. Dispose of "dead" batteries quickly, to avoid leaking and exposure to corrosive.
9. If batteries are stored in cold/freezing area to extend shelf life, protect them from condensation during storage and defrosting. Bring batteries to room temperature before using in any product.
10. Do not recharge standard batteries recommended for use with this product, also do not attempt to extend battery life by heating, they may leak corrosive electrolyte or explode.

## OPERATION

**CAUTION** REMOVE POWER BEFORE SERVICING PUMP OR SYSTEM. THE TIMER MAY TRIGGER THE PUMP TO RUN UNEXPECTEDLY DURING SERVICING WHICH MAY CAUSE CHEMICAL SPILL ACCIDENTS. ALWAYS WEAR APPROPRIATE PROTECTIVE EQUIPMENT WHEN SERVICING THE PUMP OR EQUIPMENT.

1. Check installation steps for proper completion and chemical tank for adequate supply.

2. Depress the prime button to start the pump. Chemical should begin to fill the suction tubing.
3. When all lines have been filled release the prime button.
4. Set the timer. Refer to the timer instruction on the next three pages. Just follow steps a, b, c for simple timer operation.

### PUMP TIMER PROGRAMMING INSTRUCTIONS

1. READ ALL INSTRUCTIONS FIRST.
2. When programming or re-programming, use the program work sheet to set up the desired program before entering the steps into the timer. Seeing the program on paper may avoid errors and will make it easier to put the correct steps into the timer.
3. When re-programming, it is always best to use the reset button and re-program all cycles.
4. Avoid program sequences which overlap another program. Programs which start while another program is in the 'ON' sequence will not activate.
5. An "EEE" on the screen indicates an error in program sequence. To correct, push the reset button, reset time of day and day of week, then re-program.

**CAUTION**

6. **CAUTION**: Do not attempt to re-reprogram while the timer is in the "ON" sequence unless the recessed reset button is pressed first and all sequences are reprogrammed.
7. **CAUTION**: Do not press the "⊕" button while in the "time of day" "⊖" set mode. This may cause an error in the time keeping program which will cause hours: minutes to count in seconds. If this condition occurs, slide the programming selector switch to the "⊖" position, press the "⊕" button and the 'h' button at the same time, then use the 'h' button to correct the time. When the time of day is corrected slide the programming selector switch back to the 'RUN' position.
8. **CAUTION**: Do not reset the time of day during an active cycle. Wait to reset during an "OFF" cycle or use reset button and follow the complete instruction from the beginning.
9. All programming errors may be corrected by moving the right side button to the "RUN" position and depressing the reset button 'R'. This will clear all memory, both time of day and all programs, all desired programs and time of day must be re-entered. begin again at step #1.

# PUMP TIMER PROGRAMMING INSTRUCTIONS

## Set Time of Day

1. With the programming selector switch in "RUN" position, push recessed reset button "R", "0:00" will flash on the display.
2. Slide the programming selector switch to the left to the "⌚" time of day position. "12:00" will appear on the display.
  - 2a. Use the "1..7" button to set day of week using "1" as Monday. Put the day indicator "▲" under the current day of the week.
  - 2b. Use the "h" button to set hour, "P" will appear on the left side of the display to indicate P.M.
  - 2c. Use the "m" button to set minutes.

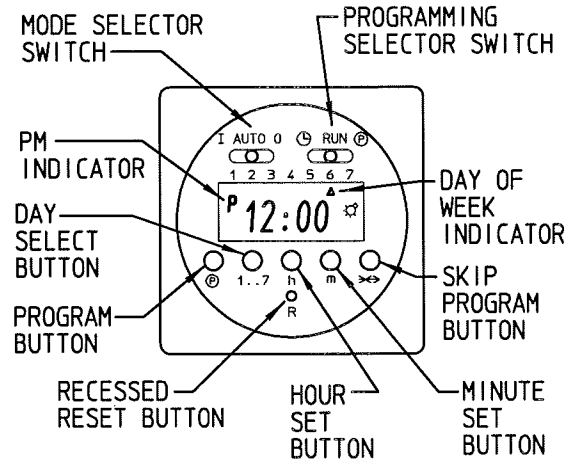

3. Slide the programming selector switch to center, "RUN", position to check time setting. The colon ":" will flash. Be certain that minutes do not change with each flash of the colon. If this condition occurs, an error has been made. Begin again at step #1.

**NOTE:** 1) Setting the time in the above sequence will clear all programs, reset the program as required. (Skip step-#1 to correct the time setting without clearing programs).

- 2) Check the clock after completion of the time setting procedure. If the clock changes minutes with each flash of the colon, an error has occurred. To correct this condition, slide the programming selector switch to the "⌚" position. Push the "Ⓟ" button and the "h" button at the same time, then push the 'h' button to advance the hours to the correct time of day. Slide the programming selector switch back to the 'RUN' position.

## Setting Programs

(Refer to program worksheet for guidance)

4. Slide programming selector switch right to program "Ⓟ" position. Screen will show "12:00 1 Ⓟ". This indicates that you are setting the first event which is the 'ON' time for first cycle.
5. Use the "1..7" button to set the desired day(or days) of the week. Put the day indicator "▲" under the day (or days) you want to run this program. Pressing the "1..7" button once will put the day indicator "▲" under Sunday(7), pressing again will move the day indicator "▲" to Monday(1). Continue pressing the button to advance day by day to Saturday(6). Press again to get multiple day programs.

### EXAMPLE:

Once = All weekdays(1 through 5),  
Twice = Weekend only(6 and 7),  
3-Times = Every day except Sunday(1 through 6),  
4-Times = Every day(1 through 7).

- 5a. Use the 'h' button to set hour, remember to set the time in A.M. or P.M. as required.
- 5b. Use the 'm' button to set minutes.

# PUMP TIMER PROGRAMMING INSTRUCTIONS

## SETTING PROGRAMS(continued)

6. Push the program button “Ⓟ” to enter this data and set “ON” time. The display will change to “12:00 2” ready for you to set “OFF” time for first program.
7. Use the “1..7” button to set the day or days of the week for the “OFF”-cycle(refer to step-#5 above). Day or days should match the day or days used in previous “ON”-cycle setting.
  - 7b. Set “OFF” time for first program using the “h” and “m” buttons.
8. After setting time to desired “OFF” time, press the “Ⓟ” button. This completes program-1. “12:00 3 Ⓞ” will appear on the display ready to set on “ON” time for next program.
9. If further programs are desired, continue setting program using Steps 5 through 8.
  - 9a. If programming is complete, slide the program selector switch back to the “RUN” position. All programs are now active.
10. To review program setting slide program selector switch to the “Ⓟ” position. The display will show “xx:xx 1 Ⓞ” indicating the first “ON”-cycle, day and time. Press the “Ⓟ” button again and the display will show “xx:xx 2”, the first “OFF”-cycle, day and time. Continue pressing the “Ⓟ” button to step thru the “ON” and “OFF” cycles of the rest of the program. After cycle-8 “xx:xx 8” is passed the display will return to the first cycle. The program selector switch may be returned to the run position at anytime during review.

### Running the pump

11. Position the mode selector switch (“I”, “AUTO”, “O”) to the position desired.

In position “I”, the pump will run pump continuously, regardless of the program

In position “AUTO”, the pump will follow the program sequence.

In position “O”, the pump will always remain off, regardless of the program.

12. Skip cycle button “⌘→” may be used when you want to skip all program sequences programmed for the next day. Press the “⌘→” button once. The “⌘→” will appear in the lower right corner of the display. This will stop all program cycles from running the next calendar day(the day indicator “▲” will flash during the day which is being skipped).

# PROGRAM WORKSHEET

! CAUTION !: SET TIME OF DAY PRIOR TO PROGRAMMING

PROGRAM	DAY(or DAYS)						
	1	2	3	4	5	6	7
1 ON 1 ☼							
1 OFF 2							
2 ON 3 ☼							
2 OFF 4							
3 ON 5 ☼							
3 OFF 6							
4 ON 7 ☼							
4 OFF 8							
5 ON 9 ☼							
5 OFF 10							
6 ON 11 ☼							
6 OFF 12							
7 ON 13 ☼							
7 OFF 14							
8 ON 15 ☼							
8 OFF 16							

AS SEEN IN AUTOMATIC RUN CONDITION AT 2:00 PM WITH PUMP RUNNING

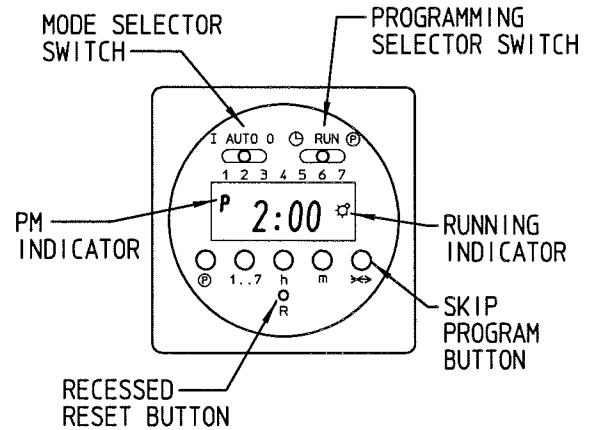

AS SEEN TO SET ON TIME

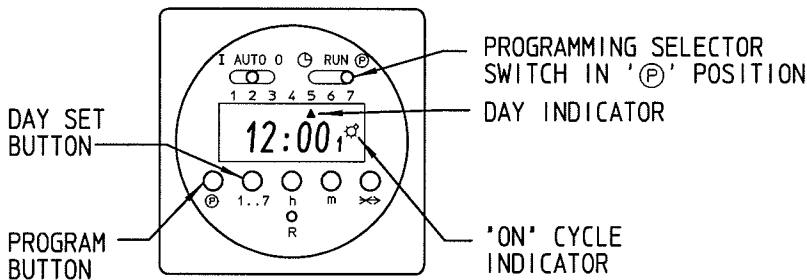

AS SEEN TO SET OFF TIME

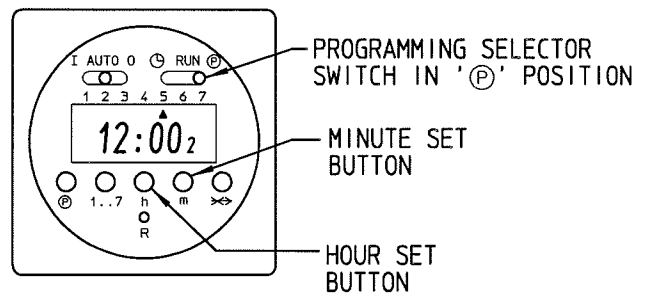

TO SET DAY OF WEEK, PRESS '1...7' BUTTON TO MOVE DAY INDICATOR '▲' TO DAY DESIRED(or DAYS). NOTE: ANY INDIVIDUAL DAY IS AVAILABLE, MULTIPLE DAY PROGRAMS ARE LIMITED TO THOSE SHOWN BELOW. SEE "SETTING PROGRAM", STEP 5A.

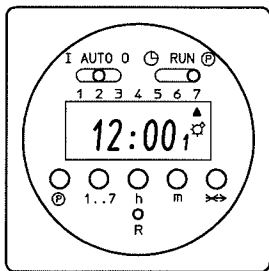

RUN SUNDAY

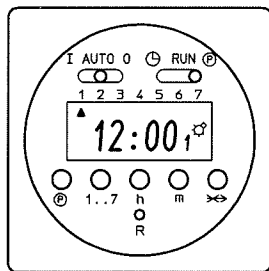

RUN MONDAY

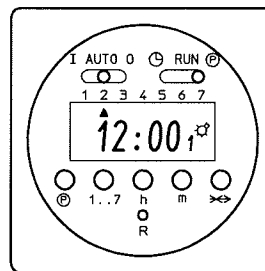

RUN TUESDAY

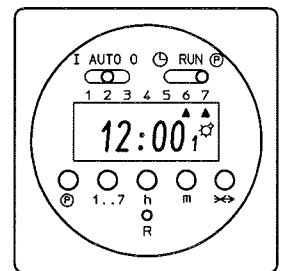

RUN SATURDAY & SUNDAY

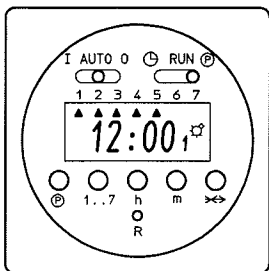

RUN ALL WEEK DAYS

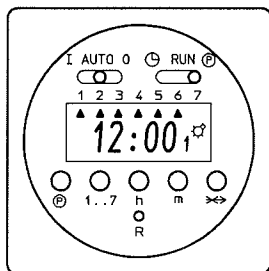

RUN EVERY DAY EXCEPT SUNDAY

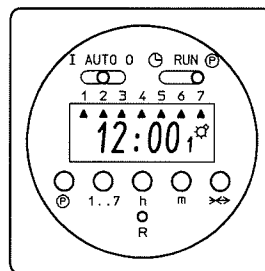

RUN EVERY DAY

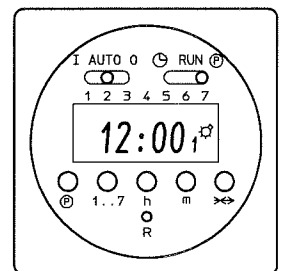

NO DAYS! WILL NOT RUN THIS PROGRAM



# EXPLODED ASSEMBLY

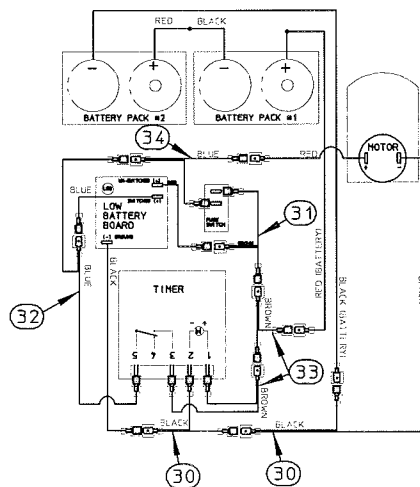
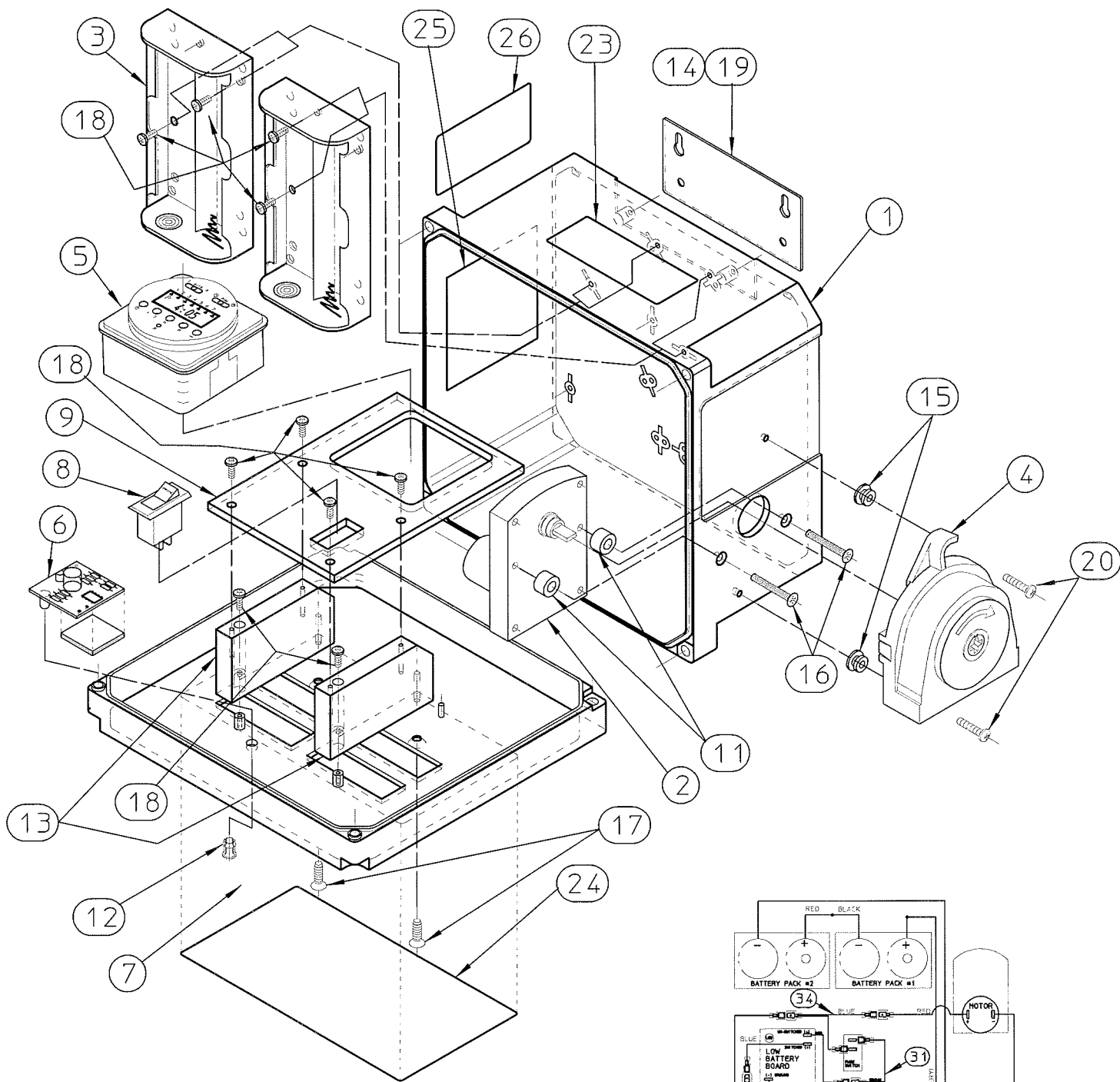

# WIRING DIAGRAM

**FIGURE #4**

## ASSEMBLY PARTS LIST(continued)

ITEM	PART #	PART DESCRIPTION	QTY
AS'Y	UT24-AD-	2400T-DC BATTERY PERISTALTIC PUMP	REF
1	U0819362	ENCLOSURE(ABS-BLK) AS'Y	1
2	U0818881	MOTOR, 12VDC, 2400T-DC	1
3	U0818902	BATTERY HOLDER AS'Y, 2400T-DC	1
4	U0818932	HEAD AS'Y, w/PAD LG.-SPACER 2400T-DC PERI	1
5	U0819037	TIMER, DIG./AMPM/12VDC/W/DIN	1
6	U0818903	PCB AS'Y, 2400T-DC LOW BATTERY	1
a	U0020522	TAPE, .13 x 2.0in.-WIDE FOAM DBL-SIDED	REF
7	U8800329	LOCK KIT, 2400T-DC KEYED	option
a	U0818878	LOCK AS'Y, w/KEY	1
b	U0819373	BRACKET, LOCK LATCH	REF
	U0020554	GUIDE(ABS-GRY), .25 x .6 x 2.0in.-LG.	2.0in.
8	U0818061	SWITCH,/PRIMR TA 10B-TR-8-XME	1
9	U0819356	PANEL(ABS-BLK), 2400T-DC CONTROL	1
11	NC980005-000	SPACER(NYL), .257-ID x .5-OD x .31in.-LG.	2
12	09-096-00	MOUNT(BLK), LED CLIP	1
13	U0819357	BLOCK(PE-WHT), PANEL SPACER	2
14	U0819318	PLATE(SST), 2400T-DC MOUNTING w/SCREWS	1
15	U0819132	COLLAR(SST), PERI HEAD MOUNT	2
16	U0818666	SCR(SST), #8-32X 1.25in.-LG. FHP	2
17	U0817942	SCR(SS), #10-32 x .75-LG. TYPE-F FHP	2
18	U0900857	SCR(SST), #6-20 x .38 TYPE-BT PHP	10
19	U0818206	SCREW(SST), #6-32 x .38in.-LG. FHP	2
20	L9800200-188	SCREW(SST), #8 x .75in.-LG. SELFTAP PHP	2
23	U0818971	LABEL, CAUTION(REMOVE BATTERY) DECAL	1
24	U0819277	LABEL, LOGO/MOM/2400T-DC DECAL	1
25	U0818954	LABEL, LOW BATT 2400T-DC DECAL	1
26	U0818925	LABEL, DATA 2400T-DC NO-LOGO/APPROVALS	1
29	J42310	TIE(NYL), WIRE .1in.-wide X 3.0in.-LG.	3
30	NC970016-000	'Y'-LEAD(BLK) AS'Y, 2.0in.-LG.M(1)xF(2)	2
31	NC970017-000	'Y'-LEAD(BRN) AS'Y, 4.0in.-LG.M(1)xF(2)	2
32	NC970018-000	'Y'-LEAD(BLU) AS'Y, 4.0in.-LG.M(1)xF(2)	2
33	NC970019-000	'Y'-LEAD(BRN) AS'Y, 2.0in.-LG.M(1)xF(2)	2
34	L9710500-000	'Y'-LEAD(BLU) ASY, 2.0x4.0in.-LG.M(1)xF(2)	1
39	U0818895	TUBE .25in.X.170in X 20FT.PE	1
40	U0818893	LIT.KIT, 2400T-DC, .44-NOR(BLK)	REF
	U0818950	LIT.KIT, 2400T-DC, .44-VITON(CREAM)	REF
		COLLARS, CLAMPS, FEET, HEAD TUBING, MANUAL, INJ. VALVE ASY, STRAINER ASY,	
41	U8800330	SCREW KIT, THUMB KNOB w/RETAINING WSHR	option
a	L9802600-188	SCREW(SST), #10-32 x 1.25in.-LG. SHCS	2
b	NC190000-000	KNOB(BLK), #10 THUMB SCREW	2
c	U0818026	SPACER(STL), .38x.19x.355in.-LG.	2
d	03-005-16-E	WASHER(NYL), .275-OD x .175-ID x .02-THK	2

# ASSEMBLY PARTS LIST(WET END)

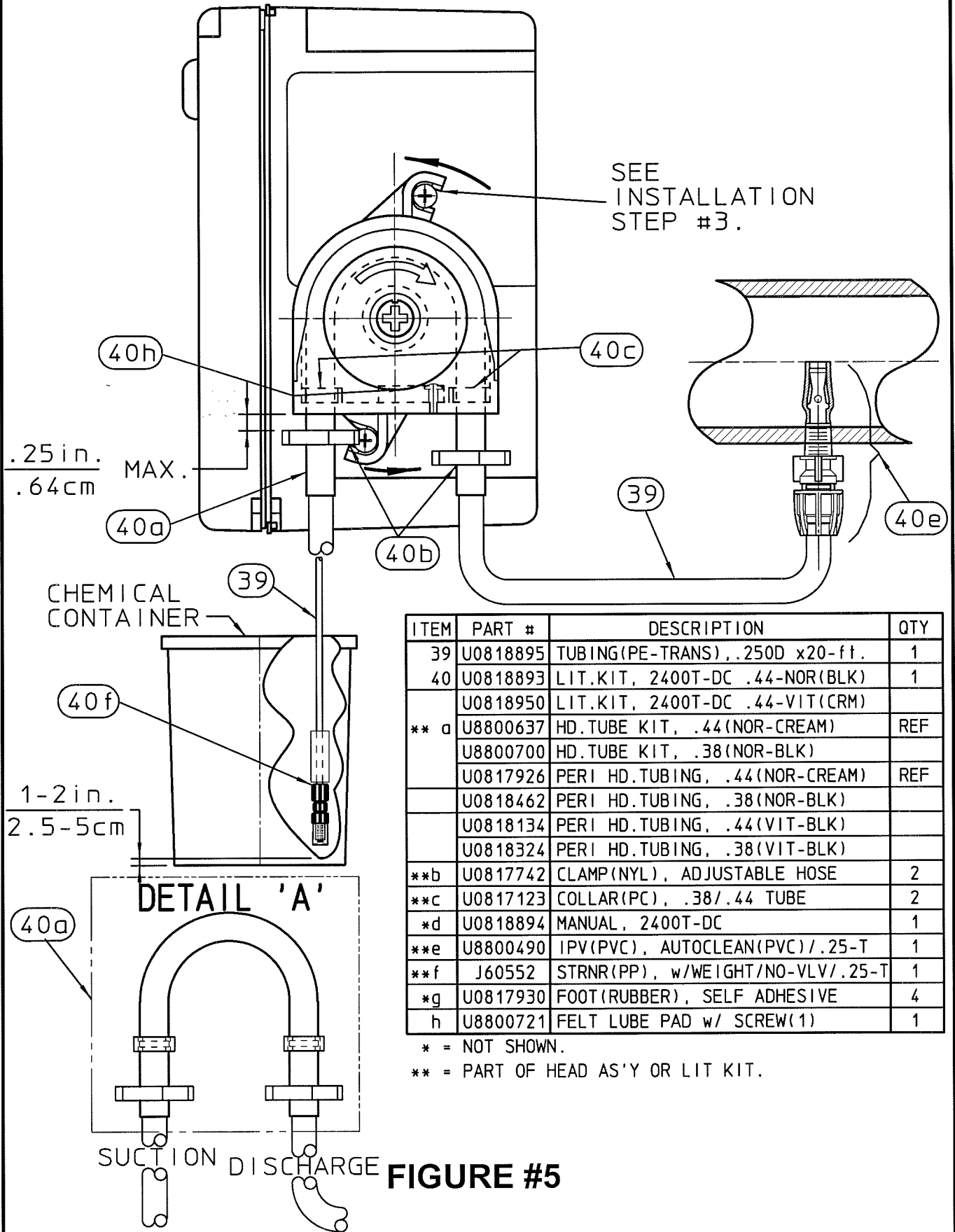

ITEM	PART #	DESCRIPTION	QTY
39	U0818895	TUBING(PE-TRANS), .250D x20-ft.	1
40	U0818893	LIT.KIT, 2400T-DC .44-NOR(BLK)	1
	U0818950	LIT.KIT, 2400T-DC .44-VIT(CRM)	
** a	U8800637	HD.TUBE KIT, .44(NOR-CREAM)	REF
	U8800700	HD.TUBE KIT, .38(NOR-BLK)	
	U0817926	PERI HD.TUBING, .44(NOR-CREAM)	REF
	U0818462	PERI HD.TUBING, .38(NOR-BLK)	
	U0818134	PERI HD.TUBING, .44(VIT-BLK)	
	U0818324	PERI HD.TUBING, .38(VIT-BLK)	
**b	U0817742	CLAMP(NYL), ADJUSTABLE HOSE	2
**c	U0817123	COLLAR(PC), .38/.44 TUBE	2
*d	U0818894	MANUAL, 2400T-DC	1
**e	U8800490	IPV(PVC), AUTOCLEAN(PVC)/.25-T	1
**f	J60552	STRNR(PP), w/WEIGHT/NO-VLV/.25-T	1
*g	U0817930	FOOT(RUBBER), SELF ADHESIVE	4
h	U8800721	FELT LUBE PAD w/ SCREW(1)	1

\* = NOT SHOWN.

\*\* = PART OF HEAD AS'Y OR LIT KIT.

**FIGURE #5**

### WARRANTY:

The manufacturer warrants its equipment of its manufacture to be free of defects in material or workmanship. Liability under this policy extends to eighteen(18) months from the date of purchase or one(1)-year from date of installation or whichever comes first. The manufacturer's liability is limited to repair or replacement of any device or part, which is returned, prepaid, to the factory and which is proven defective upon examination. This warranty does not include installation or repair costs and in no event shall the manufacturer's liability exceed the selling price of such part.

The manufacturer disclaims all liability for damage to its products through improper installation, maintenance, use or attempts to operate such products beyond their functional capacity, intentionally or otherwise, or any unauthorized repair. Replaceable elastomeric parts are expendable and are not covered by any warranty either expressed or implied. The manufacturer is not responsible for consequential or other damages, injuries or expense incurred through use of its products.

The above warranty is in lieu of any other warranty, either expressed or implied. The manufacturer makes no warranty of fitness or merchantability. No agent of ours is authorized to make any warranty other than the above

